

Effective : November 1999

Supersedes 41-490H Dated March 1997

(|) Denotes Change Since Previous Issue

Type KD-10 and KD-11 Compensator Distance Relay



Before putting protective relays into service, make sure that all moving parts operate freely, inspect the contacts to see that they are clean and operate the relay to check the settings and electrical connections.

1.0 APPLICATIONS

The type KD-10 relay (Figure 1, page 35), is a polyphase compensator type relay which provides a single zone of phase protection for all three phases. It provides essentially instantaneous tripping for phase-to-phase faults, two-phase-to-ground faults, and three-phase faults within the reach setting and sensitivity level of the relay.

The type KD-11 relay (Figure 1), is similar to the KD-10 relay except that the characteristic impedance circle for the 3-phase unit includes the origin. This relay is usually applied as a carrier start relay in directional comparison blocking schemes but it may also be used for time delay tripping in non pilot distance relaying. Both KD-10 and KD-11 relays have indicating contactor switches rated 0.2/2.0 amperes. The 2.0 ampere tap must be used for directional comparison blocking (KA-4) applications. The 2.0 ampere target is recommended for direct trip applications. The 0.2 ampere target is recommended where a 125 or 250 volt lockout relay (WL) is energized and 2.0 ampere where a 48 volt lockout relay is used.

Refer to Instruction Leaflet 40-208 for a description of how the KD-10 relay is used in directional comparison blocking systems.

For time-distance applications the KD-10 and KD-11 relays are used with the TD-4, TD-52 or TD-5 dc tran-

sistorized timers. See Figure 19 (page 50) and Figure 24 (page 53) for the external schematics for 3 zone protection, using the TD-4 and TD-52 relays, respectively. For further discussion see Section 9, External Connections.

Fault detectors are used to supervise the trip circuit for those applications where line side potentials are used or loss-of-potential supervision is desired. Otherwise, undesired tripping may occur on line oscillations or loss-of-potential. The cylinder type KC-2 or KC-4 relay (2-8 amperes) is recommended. The plunger or other magnetic attraction type relays (e.g., a three unit SC relay or a three unit ITH relay) may be used if the fault detector contacts carry trip coil current rather than auxiliary relay (e.g., auxiliary trip unit, timer, etc.) current.

The SC or ITH relay may also be used if a slow dropout contact (e.g., TX contact of TD-5 timer relay) is available to be connected around the fault detector contacts.

2.0 CONSTRUCTION

The type KD-10 and KD-11 relays consist of the following: three single air gap transformers (compensators, Figure 2, page 36), three tapped auto-transformers, two cylinder type operating units, and an ICS indicating contactor switch.

2.1 COMPENSATOR

The compensator, which is designated T (Figure 3, page 36), is a two-winding air gap transformer with one primary current winding. The compensators, which are designated T_{AB} and T_{BC} , are three-winding air gap transformers with two primary current windings. Each primary current winding has seven

All possible contingencies which may arise during installation, operation or maintenance, and all details and variations of this equipment do not purport to be covered by these instructions. If further information is desired by purchaser regarding this particular installation, operation or maintenance of this equipment, the local ABB Power T&D Company Inc. representative should be contacted.

taps which terminate at the tap block (Figure 3, page 36). They are marked:

Relay – Ohms	Taps						
0.2-4.5	0.23	0.307	0.383	0.537	0.690	0.920	1.23
0.75-21.2	0.87	1.16	1.45	2.03	2.9	4.06	5.8
1.27-36.6	1.5	2.0	2.5	3.51	5.0	7.02	10.0

Current flowing through the primary coil provides an MMF which produces magnetic lines of flux in the core.

A voltage is induced in the secondary which is proportional to the primary tap and current magnitude. This proportionality is established by the cross sectional area of the laminated steel core, the length of an air gap which is located in the center of the coil, and the tightness of the laminations. All of these factors which influence the secondary voltage proportionality have been precisely set at the factory. The clamps which hold the laminations should not be disturbed by either tightening or loosening the clamp screws.

The secondary winding has a single tap which divides the winding into two sections. One section is connected subtractively in series with the relay terminal voltage. Thus a voltage which is proportional to the phase current is subtracted vectorially from the relay terminal voltage. The second section is connected to a potentiometer and a fixed loading resistor and provides a means of adjusting the phase angle relation between primary current and the induced secondary voltage.

2.2 AUTO-TRANSFORMER

The auto-transformer has three taps on its main winding, S, which are numbered 1, 2 and 3 on the tap block. A tertiary winding M has four taps which may be connected additively or subtractively to inversely modify the S setting by any value from -18 to +18 percent in steps of 3 percent.

The sign of M is negative when the R lead is above the L lead. M is positive when L is in a tap location which is above the tap location of the R lead. The M setting is determined by the sum of per unit values between the R and L lead. The actual per unit values which appear on the tap plate between taps are 0, .03, .09 and .06.

The auto-transformer makes it possible to expand the basic range of "T" ohms by a multiplier of $\frac{S}{1 \pm M}$.

Therefore, any relay ohm setting can be made within 1.5 percent from the desired value by combining the compensator taps T, T_{AB}, and T_{BC} with the auto-transformer taps S and M, S_A and M_A, and S_C and M_C. See Tables I, II, and III for compilation of settings available (page 13, page 14, & page 15).

2.3 TRIPPING UNIT

The device which acts to initiate tripping is a four-pole cylinder unit which is connected open delta and operates as a three-phase induction motor. Contact-closing torque is produced by the unit when the voltage applied to its terminals has a negative-phase sequence. Closing torque for the relay forces the moving contact to the left hand side as viewed from the front of the relay. Contact-opening torque is produced when positive-phase sequence voltages are applied. Hence, the cylinder unit has restraint or operating torque as determined by the phase sequence of the voltages applied to its terminals.

Mechanically, the cylinder unit is composed of three basic components: a die-cast aluminum frame and electromagnet, a moving element assembly, and a molded bridge.

The frame serves as the mounting structure for the magnetic core. The magnetic core which houses the lower pin bearing is secured to the frame by a spring and snap ring. This is an adjustable core which has a 0.020 inch flat on one side and is held in its adjusted position by the clamping action of two compressed springs. The bearing can be replaced, if necessary, without having to remove the magnetic core from the frame.

The electromagnet has two series-connected coils mounted diametrically opposite one another to excite each set of poles. Locating pins on the electromagnet are used to accurately position the lower pin bearing, which is mounted on the frame, with respect to the upper pin bearing, which is threaded into the bridge. The electromagnet is permanently secured to the frame and cannot be separated from the frame.

The moving element assembly consists of a spiral spring, contact carrying member, and an aluminum cylinder assembled to a molded hub which holds the shaft. The hub to which the moving contact arm is clamped has a wedge-and-cam construction, to provide low-bounce contact action. A casual inspection

of the assembly might lead one to think that the contact arm bracket does not clamp on the hub as tightly as it should. However, this adjustment is accurately made at the factory and is locked in place with a lock nut and should not be changed.

The shaft has removable top and bottom jewel bearings. The shaft rides between the bottom pin bearing and the upper pin bearing which is adjusted to .025 inch from the top of the shaft bearing. The cylinder rotates in an air gap formed by the electromagnet and the magnetic core.

The bridge is secured to the electromagnet and the frame by two mounting screws. In addition to holding the upper pin bearing, the bridge is used for mounting the adjustable stationary contact housing. This stationary contact has .0015 to .0035 inch follow which is set at the factory by means of the adjusting screw. After the adjustment is made the screw is sealed in position with a material which flows around the threads and then solidifies. The stationary contact housing is held in position by a spring type clamp. The spring adjuster is located on the underside of the bridge and is attached to the moving contact arm by a spiral spring. The spring adjuster is also held in place by a spring type clamp.

The main contact of KD-10 and KD-11 relays will close 30 amp at 250 Vdc and the seal-in contact of the indicating contactor switch will carry this current long enough to trip a breaker.

When the contacts close, the electrical connection is made through the stationary contact housing clamp, to the moving contact, through the spiral spring and out to the spring adjuster clamp.

2.4 INDICATING CONTACTOR SWITCH UNIT (ICS)

The indicating contactor switch is a small dc operated clapper type device. A magnetic armature, to which leaf-spring mounted contacts are attached, is attracted to the magnetic core upon energization of the switch. When the switch closes, the moving contacts bridge two stationary contacts, completing the trip circuit. Also during this operation two fingers on the armature deflect a spring located on the front of the switch, which allows the operation indicator target to drop. The target is reset from outside of the case by a push rod located at the bottom of the cover.

The front spring, in addition to holding the target, provides restraint for the armature and thus controls the pickup value of the switch.

3.0 OPERATION

The KD-10 relay has two major components: compensators and tripping units. In the internal schematic of Figure 4 (page 37) the compensators are designated T, T_{AB} and T_{BC}, the tripping units, Z (3 ϕ) and Z ($\phi\phi$). The phase-to-phase unit, Z ($\phi\phi$) operates for all combinations of phase to phase faults (phase A-B, B-C, and C-A). The 3-phase unit Z (3 ϕ) operates for 3-phase faults and for close-in-two-phase-to-ground faults, although most two-phase-to-ground faults are cleared by operation of the phase-to-phase unit. Each of the tripping units and its associated compensator circuit are electrically separate, and will now be considered successively.

3.1 THREE-PHASE UNIT

A single compensator T has its primary energized with $(I_A - 3I_0)$ current; $3I_0$ is the residual current. (See External Schematic, Figure 19, page 50.) There are three compensators shown one for each of the three zones. One connection uses an auxiliary 5:5 ratio current transformer to insert the $-3I_0$ component. The alternate connection supplies the compensator primaries with $(-I_B - I_C)$. Since $I_A + I_B + I_C = 3I_0$, $(I_A - 3I_0) = (-I_B - I_C)$. Current I_A , I_B and I_C are the phase currents. The $3I_0$ current is needed to provide overlap with the $\phi\phi$ unit on 2-phase-to-ground faults.

Accordingly, the alternate connection is equivalent to the first arrangement. Note that relay 21-3, a type KD-11, also has a current winding Z. This winding is wound on the tripping unit so that the R-X diagram circle includes the origin, as explained under Section 4, Characteristics.

As shown in Figure 19 (page 50), the T compensator secondary is connected to modify the phase A voltage. With a fault in the trip direction, the induced voltage in the compensator secondary bucks the phase A voltage.

Vector diagrams in Figure 8 (page 40) illustrate the operation during 3-phase faults at four locations. The system impedance and the compensator angle are assumed to be at 90° for illustrative purposes only. Prefault voltages are depicted by the large dashed triangle. The smaller dashed triangle in each case is the system voltages at the relay location during the fault. This triangle is modified by the compensator voltage $-1.5I_A T$ where $1.5T$ is the compensator mutual impedance. The terminals of the tripping unit are designated: X, Y and Z. Phase A tripping unit voltage is:

$$V_X = 1.5 V_{AN} - 1.5 I_A T \quad [\text{Equ. 1}]$$

$$\text{Note that } 3I_0 = 0 \text{ for 3-phase faults} \quad [\text{Equ. 2}]$$

Phase B and phase C tripping unit voltages are:

$$V_Y = V_{BN} \quad [\text{Equ. 3}]$$

$$V_Z = V_{CN} \quad [\text{Equ. 4}]$$

For a fault at A, beyond the relay operating zone, the compensator voltage, $-1.5I_A T$ modifies the phase A voltage, reducing the voltage triangle of the tripping unit to X-Y-Z. With an X-Y-Z rotation the tripping unit torque is in the restraining direction.

For a fault at B the current is larger than for a fault at A, so that $-1.5I_A T$ is larger. The point X is in line with points Y and Z. No torque is produced, since the X-Y-Z triangle has a zero area.

For a fault in the operating zone, such as at C, point X is below the YZ line. Now the rotation is X, Z, Y, which produces operating torque.

For a fault behind the relay at D, restraining torque is produced. Since the fault is behind the relay the current is of reversed polarity. Compensator voltage, $-1.5I_A T$, increases the area of the bus voltage triangle, A-B-C. Tripping unit voltage has an X-Y-Z rotation which produces restraining torque.

A solid 3-phase fault at the relay location, tends to completely collapse the A-B-C voltage triangle. The area of the X-Y-Z triangle also tends to be zero under these conditions. A memory circuit in the KD-10 relay provides momentary operating torque under these conditions, for an internal fault. In the KD-11 relay the winding Z in the current circuit, in conjunction with the compensator voltage, produces a current-only torque, which maintains operating torque under the condition of zero potential. In the short reach relay the offset is obtained by means of an additional compensator T_{BR} .

The $P_{3A} - R_{3F}$ parallel resistor-capacitor combination in the compensated phase provides correct phase-angle relation between the voltage across the front and back coils of Z (3ϕ) and the current, similar phase shift is produced in left and right hand coils by capacitor C_{3C} . The $P_{3A} - C_{3A}$ combination also provides control of transients in the coils of the cylinder unit.

3.2 PHASE-TO-PHASE UNIT

Compensator primaries of T_{AB} and T_{BC} are energized by I_A , I_B and I_C as shown in Figure 19

(page 50). Compensator secondaries are connected to modify their respective phase voltages (e.g., T_{AB} modifies V_{AB}). With a fault in the trip direction, the induced voltages in the compensator secondaries buck the phase-phase voltages.

Vector diagrams in Figure 9 (page 41) illustrate the operation during phase B-C faults at four locations. The system impedances and the compensator angle are assumed to be at 90° , for illustrative purposes.

Prefault voltages are depicted by the large dashed triangles. The smaller light triangle in each case is the system voltages at the relay location during the fault. This triangle is modified by the compensator voltages $-(I_A - I_B) Z_C$ and $-(I_C - I_B) Z_C$. Z_C is the compensator mutual impedance. In this case $I_A = 0$. The terminals of the tripping unit are designated; X, Y, and Z. Tripping unit voltages for phase B-C faults are:

$$V_{XY} = V_{AB} - (I_A - I_B) Z_C \quad [\text{Equ. 5}]$$

$$V_{ZY} = V_{CB} - (I_C - I_B) Z_C \quad [\text{Equ. 6}]$$

For a fault at A, in Figure 9 (page 41) beyond the relay operating zone, the compensator voltages change the A-B-C voltage sequence to the X-Y-Z sequence. Voltages of this sequence applied to operating unit produce restraining torque.

For a fault at B, the currents are larger than for a fault at A, so that compensator voltages are larger. Points Y and Z coincide now and the area of the X-Y-Z triangle is zero. No torque is produced.

For a fault in the operating zone, such as at C, the compensator voltages reverse the rotation of tripping unit voltages to X-Z-Y sequence. Voltages of this sequence applied to operating unit produce operating torque.

For a fault behind the relay at D, restraining torque is produced. Since the fault is behind the relay, the current is of reverse polarity and tripping unit voltage has an X-Y-Z rotation. This rotation produces restraining torque.

Note that this unit does not require memory action, since the sound-phase voltage reacts with the compensator voltage to produce a strong restraining or a strong operating torque, depending upon the fault location. This is true even for a complete collapse of the faulted phase-to-phase voltage. The phase-to-phase unit is identical in the KD-10 and KD-11 relays.

Similar vector diagrams apply for a fault between phases A and B or between phases C and A. Each

of the three phase-to-phase fault combinations subjects the cylinder unit to a similar set of conditions.

4.0 CHARACTERISTICS

4.1 DISTANCE CHARACTERISTICS PHASE-TO PHASE UNIT

This unit responds to all phase-to-phase faults and most two-phase-to-ground faults. It does not respond to load current, synchronizing surges, or out-of-step conditions. While a characteristic circle can be plotted for this unit on the R-X diagram, as shown in Figure 10 (page 42), such a characteristic circle has no significance except in the first quadrant where resistance and reactance values are positive. A small portion of the fourth quadrant, involving positive resistance values and negative reactance values, could have some significance in the event that the transmission line includes a series capacitor. The portion of the circle in the first quadrant is of interest because it describes what the relay will do when arc resistance is involved in the fault. The phase-to-phase unit operating on an actual transmission system is inherently directional and no separate directional unit is required.

An inspection of Figure 10 (page 42) indicates that the circle of the phase-to-phase unit is dependent on source impedance Z_S . However the circle always goes through the line balance-point impedance. The reach at the compensator (and line) angle is constant, regardless of the system source impedance. The broadening out of the characteristic circle with a relatively high source impedance gives the phase-to-phase unit the advantageous characteristic that for short lines, it makes a greater allowance for resistance in the fault. Stated another way, the characteristics approach that of a reactance relay more and more closely as the line being protected becomes shorter and shorter with respect to the source impedance back of the relaying location.

4.2 SENSITIVITY: PHASE-TO-PHASE UNIT

A plot of relay reach, in percent of tap block setting, versus relay terminal voltage and current sensitivity is shown in Figure 12 (page 42). The unit will operate with the correct directional sense for zero voltage phase-to-phase faults. For this condition the fault current must be not less than 0.015 relay amperes with an ohm setting of 5.8 with rated voltage on the unfaulted phase. Pick up current is proportionately higher in S=2 and S=3 taps.

The KD-10 relay may be set without regard to possible overreach due to dc transients. Compensators basically are insensitive to dc transients which attend faults on high angle systems. The long time constant of a high angle system provides a minimum rate of change in flux-producing transient current with respect to time, and therefore induces a minimum of unidirectional voltage in the secondary. Asymmetrical currents resulting from faults on low-angle systems having a short time constant can induce considerable voltage in the secondary, but for the first half cycle, the transient-derived voltage subtracts from the steady-state value. This transient decays so rapidly that it is insignificant during the second half cycle when it adds to the steady-state value.

4.3 DISTANCE CHARACTERISTIC – KD-10, 3-PHASE UNIT

The three-phase unit has a characteristic circle which passes through the origin as shown in Figure 11 (page 42). This circle is independent of source impedance. The three-phase unit is also inherently directional and does not require a separate directional unit.

If a solid three-phase fault occurs right at the relay location, the entire voltage triangle collapses to zero a balance point condition, as shown by the relay characteristic in Figure 11 which passes through the origin. However, since the YZ voltage also drops to zero, the relay would be unable to determine whether an internal or external fault existed. To correct this condition, a resonant circuit is added to the C-B voltage circuit of the relay which allows the ZY voltage to determine whether the fault is inside the protected line section or behind the relay.

4.4 SENSITIVITY: KD-10, 3-PHASE-UNIT

The unit will operate with the correct directional sense for zero voltage three-phase faults when normal voltage exists at the relay terminals prior to the fault. This operation occurs due to memory action as described above. The unit will have zero torque or perhaps a slight opening torque if there is zero voltage at the relay prior to the fault or after the memory action has subsided. For medium and long reach relays with an impedance setting of 5.8 ohms the three-phase unit will directionally operate for faults which produce 2 volts line-to-line and 1.0 ampere at the relay terminals.

Sensitivity with 2 volts line-to-line for any tap is defined by Equation 7:

$$I = \frac{5.8}{T} \text{ amperes} \quad [\text{Equ. 7}]$$

For short reach relays (0.2-4.5 ohms) with an impedance setting of 1.23 ohms the three-phase unit will directionally operate for faults which produce 0.5 volts line-to-line and 2.7 ampere at the relay terminals.

Sensitivity with 0.75 volts line-to-line for any tap is defined by Equation 8:

$$I = \frac{3.4}{T} \text{ amperes} \quad [\text{Equ. 8}]$$

The KD-10 relay may be set without regard to possible overreach due to dc transients.

4.5 DISTANCE CHARACTERISTIC: KD-11, 3-PHASE UNIT

The three-phase unit of the KD-11 relay has a characteristic circle which includes the origin as shown in Figure 13 (page 43).

A single turn current coil on the cylinder unit provides for current-only torque and is small compared to the many turns of the T Max. setting of the compensator and has very little influence on the overall settings. However, as the compensator setting is reduced, the single turn current coil becomes larger by comparison and has more and more effect on the overall settings.

For 1.3–36.7 ohms range the reach and maximum torque angle will vary approximately as follows:

T Nominal	T Actual	% Overreach	MTA	Equiv. Reverse T
10	10.1	1.0	75	.13
7.02	7.13	1.5	76	.13
5.0	5.12	2.4	79	.12
3.51	3.64	3.7	82	.12
2.50	2.64	5.6	83	.11
2.00	2.14	7.2	85	.11
1.50	1.656	10.4	87	.11

For .75–21.2 ohms range the reach will vary approximately as follows:

NOTE: When setting KD-11 Relays disregard the change in T-Value, but include the percentage error into test current values.

T Nominal	T Actual	% Overreach	MTA	Equiv. Reverse T
5.8	5.92	2.2	79	.13
4.06	4.18	3.4	80	.13
2.90	3.036	7.6	82	.12
2.03	2.17	5.9	85	.12
1.45	1.615	8.3	89	.12
1.16	1.33	12	91	.11
.87	1.05	17	98	.11

The .2–4.5 ohms range KD-11 relays have no overreach regardless of the tap being used. The maximum torque angle will stay constant at 60°. The relay offset is nominal 0.1 ohms and its obtained by a compensator T_{BR}. Current-only torque is obtained through the energy provided by the T_{BR} compensator.

4.6 SENSITIVITY: KD-11, 3-PHASE UNIT

The impedance curve for the KD-11 three-phase unit is shown in Figure 12 (page 42).

The three-phase unit will operate to close the left hand contact on current-only for the following conditions:

Range (Ohms)	T Set	Minimum Amps Required
.75-21.2	5.8	3A
--	.87	7.5A
1.3-3.6	10.0	3A

For the .2–4.5 ohm range unit, the current sensitivity is defined as the product of the current and the T setting which must be equal to or greater than 6, i.e. (I x T ≥ 6).

4.7 GENERAL CHARACTERISTICS

The phase-to-phase potential rating is 120 Vac ±10%.

Impedance settings in ohms reach can be made for any value in the range of:

- 0.2 - 4.5 for **short** reach relays
- 0.75 - 21.2 for **medium** reach relays
- 1.27 - 36.6 for **long** reach relays.

The maximum torque angle for all phase-to-phase units is set for 75 degrees at the factory, and may be set for any value from 60 to 78 degrees. A change in maximum torque angle will produce a slight change in reach for any given setting of the relay. Referring

to Figure 2 (page 36), note that the compensator secondary voltage output V , is largest when V leads the primary current, I , by 90° . This 90° relationship is approached, if the compensator loading resistor (R_{2A} , or R_{2C}) is open circuited. The effect of the loading resistor, when connected, is to produce an internal drop in the compensator, which is out-of-phase with the induced voltage, IT_{AB} or IT_{AC} . Thus the net voltage, V , is phase-shifted to change the compensator maximum torque angle. As a result of this phase-shift the magnitude of V is reduced, as shown in Figure 2 (page 36). Other angles may be set by changing resistor R_{2A} and R_{2C} (or P_{2A} and P_{2C}).

The maximum torque angle of the 3-phase unit of the medium (.73 - 21.2 ohms) and the long reach (1.27 - 36.6 ohms) is set for 75 degrees at the factory, and it may be set for any value from 60 to 78 degrees. Other angles may set by changing resistor R_3 .

The maximum torque angle of the 3-phase unit of the short reach (.2 - 4.5 ohms) relay is set for 60 degrees at the factory and may be set for any value from 45 to 63 degrees. By changing R_3 (or P_3) any other angle may be set. The 90-degree setting is approached for all ranges when R_3 resistor is open circuited for the 3ϕ unit or R_{2A} and R_{2C} for the phase-to-phase unit.

Tap markings are based upon nominal settings as specified above. If the phase loading potentiometers P_3 , P_{2A} , or P_{2C} are adjusted for some other maximum torque angle, the relay reach is different from the nominal as described under settings.

5.0 TIME CURVES AND BURDEN DATA

5.1 OPERATING TIME

The speed of operation for the KD-10 relay three-phase and phase-to-phase units is shown by the time curves in Figure 14 (page 44). The curves indicate the time in milliseconds required for the relay to close its contacts for tripping after the inception of a fault at any point on a line within the relay setting.

Figure 15 (page 45) and Figure 16 (page 45) show the KD-11 operating time of the phase-to-phase unit and the three-phase unit respectively. These curves show both contact-opening time and contact-closing time for faults within the relay setting.

5.2 CURRENT CIRCUIT RATING IN AMPERES

All current circuits are rated 10 amp continuous and 1 second rating is 240 amp except for 1-37 ohm range where

- for $S = 1, T = 10$, continuous rating is 6 amp
- $S = 2, T = 10$, continuous rating is 8 amp
- $S = 3, T = 10$, continuous rating is 9 amp
- $S = 1, T = 7.02$, continuous rating is 7 amp

5.3 BURDEN

The burden which the relays impose upon potential and current transformers in each phase is shown by Figure 17 (page 46) and Figure 18 (page 48) for the KD-10 and KD-11 relays respectively. The potential burden and burden phase angle are based on 69 volts line-to-neutral applied to the relay terminals.

5.4 TRIP CIRCUIT CONSTANT

- 0.2 tap = 6.5 ohms
- 2 tap = 0.15 ohms

6.0 SETTING CALCULATIONS

Relay reach is set on the tap plate shown in Figure 3 (page 36). The tap markings are:

T, T _A , T _B , and T _C	
(Short reach) 0.23, 0.307, 0.383, 0.537, 0.690, 0.920, 1.23	
(Med. reach) 0.87, 1.16, 1.45, 2.03, 2.9, 4.06, 5.8	
(Long reach) 1.5, 2.0, 2.5, 3.51, 5.0, 7.02, 10.0	
(Values between taps)	S, S _A , and S _C
	1, 2, 3
	M, M _A , M _C
	.0, .03, .09, .06

Calculations for setting the KD-10 and KD-11 relays are straightforward and apply familiar principles. Assume a desired balance point which is 90 percent of the total length of line. The general formula for setting the ohms reach of the relay is:

$$Z = 0.9 Z_{pri} \frac{R_c}{R_v} \quad \text{[Equ. 9]}$$

The terms used in this formula and hereafter are defined as follows:

- Z = The desired ohmic reach of the relay in secondary ohms.

0.9 = The portion of the total line for which the relay is set.

R_C = Current transformer ratio

R_V = Voltage transformer ratio

Z_{pri} = Ohms per phase of the total line section

The relay tap plate setting, Z , is set according to the following Equation:

$$Z = \frac{ST}{1 \pm M} \quad [\text{Equ. 10}]$$

T = Compensator tap setting.

S = Auto-transformer primary tap setting.

$\pm M$ = Auto-transformer secondary tap setting. (This is a per unit value and is determined by the sum of the values between the "L" and the "R" leads. The sign is positive when "L" is above "R" and acts to lower the Z setting. The sign is negative when "R" is above "L" and acts to raise the Z setting.)



The tap plate values of Tables I, II, and III are based on standard maximum torque angle settings.

In general recalibration of the relay to a torque angle other than the standard value is neither desirable nor required. Where it is necessary, the phase loading potentiometers P3, P2A, or P2C can be adjusted for other maximum torque angle. The relay reach then becomes different from the nominal tap plate settings and tap plate setting should be modified as outline under Section 6.2, Maximum Torque Angle Consideration.

6.1 OBTAINING AN OPTIMUM SETTING

- a. Establish Z , as per Equation 9.
- b. Now refer to Table I, II, or III (page 13, page 14, & page 15). These tables list optimum settings for the relay.
 - 1) Locate a table value for relay reach nearest to the desired value Z (it will always be within 1.5% or less off the desired value).

- 2) Read off the Table "S", "T" and "M" settings. The "M" column includes additional information for "L" and "R" leads setting for the specified "M" value.

- 3) Recheck the S, T, & M settings by using Equation 10.

Example 1

Step 1

Assume the desired reach, Z is 7.8 ohms at 75° .

Step 2a

In Table II (page 14) we find nearest value to 7.8 ohms 7.88 that is $100 \times \frac{7.88}{7.8} = 101$ percent of the desired reach.

Step 2b

From Table II (page 14) read off:

$$\begin{aligned} S &= 2 \\ T &= 4.06 \\ M &= +.03 \end{aligned}$$

and "L" lead should be connected over "R" lead, with "L" lead connected to ".03" tap and "R" lead to tap "0".

Step 2c

Recheck Settings.

$$Z = \frac{ST}{1 \pm M} = \frac{2 \times 4.06}{1 + .03} = 7.88$$

6.1.1 Checking Relay Settings Using Reverse Procedures

Tables I, II, or III can be used to check relay settings in the field using the following reverse procedures:

1. Read off the tap plate T, S, M settings.
2. Find corresponding Z value from appropriate tables.

6.2 MAXIMUM TORQUE ANGLE CONSIDERATIONS

For **Medium** and **Long Reach Relays** maximum torque angle is set at the factory for 75 degrees current lagging voltage.

For **Short Reach Relays** the maximum torque angle of the three-phase unit is set for 60 degrees and the phase-to-phase unit for 75 degrees.

6.2.1 Guidelines to Achieve Optimum Application of the Relay to the Lines to be Protected

- a. For Zone 1 application of KD-10 relays no setting or calibration correction should be made if the line angle is 65 degrees or higher for the medium and long range relays (50 degrees for the short range relay).
- b. For pilot trip or timed trip (Zone 2 or 3, or KD-11) applications no setting or calibration correction is required regardless of the difference between the relay and line angle.
- c. For line angles below 65° for long and medium reach KD-10 relays the difference between the relay and line angles can be accounted for without recalibration of the relay by matching the relay impedance setting to the desired impedance value of the line. (The recalibration of the relay to the lower angle may be undesirable because the load that can be accommodated by the 3φ unit is lower. See Figure 11, page 42.) The phase-to-phase unit is not responsive to load flow.

The setting calculations are done as follows:

If Z-line is the desired reach of the relay, the Z (the relay setting) is

$$Z = \frac{Z \text{ line}}{\cos(\Theta_m - a)} \quad [\text{Equ. 11}]$$

Where m is the maximum torque angle of the relay

a = Line Angle

Example 2

If the desired reach is 5 ohms at 60°, a KD-10 relay having an MTA of 75° should be set for:

$$Z = \frac{5}{\cos(75^\circ - 60^\circ)} = \frac{5}{\cos 15^\circ} = 5.18 \text{ ohms}$$

or referring to Table II (page 14) relay should be set: S = 1, T = 5.8, M = +.12.

6.2.2 For Short Range Relay (.2 - 4.5 ohms)

Zone 1 application for line angles below 50, recalibrate the phase-to-phase unit to maximum torque angle of 60° and the 3-phase unit for 45 degrees. Set Zone 1 and reach for 90% of the line (85% for line angles of less than 50°). In this case, follow the procedure below: Recalibrate the relay for the new maximum torque angle and set relay reach Z to be:

$$Z = \frac{Z \text{ line} \sin \theta_m}{\sin \theta} \quad [\text{Equ. 12}]$$

- where θ_m - original maximum torque angle of the relay
- θ - the new maximum torque angle after relay recalibration
- Z line - desired reach
- "T" - values should be modified by the ratio $(\sin \theta / \sin \theta_m)$ to obtain the actual value of T.

Example 3

- a. Original nominal relay maximum torque angle (short range relay).

m = 75° for phase-to-phase unit
m = 60° for three-phase unit

- b. The desired reach is 0.5 ohms at 45°
- c. Calculate settings: (Use Equation 12)

For phase-to-phase unit, recalibrated for 60°

$$Z = \frac{0.5 \sin 75^\circ}{\sin 60^\circ} = 0.557 \text{ ohms}$$

For 3-phase unit, recalibrated for 45°

$$Z = \frac{0.5 \sin 60^\circ}{\sin 45^\circ} = 0.612 \text{ ohms}$$

Referring to Table I (page 13), use closest setting for phase-to-phase unit:

T_A, T_B, T_C = .537
M_A, M_C = -.06
S_A, S_C = 1

For 3-phase unit closest setting:

T = .690
M = +.12
S = 1

NOTE: If for some reasons an exact correction is required to match up the line impedance Z_L at an angle α , and the relay has been recalibrated from nominal maximum torque to a new maximum torque angle $\beta \neq \alpha$, then the relay setting Z should be equal to:

$$Z = \frac{Z_{Line} \sin \theta_m}{\sin \beta \cos(\beta - \alpha)} \quad [\text{Equ. 13}]$$

Example 4

Relay with original $\theta_m = 75^\circ$ has been recalibrated to 60° and to be applied to 5 ohm-line with line angle $a = 50^\circ$.

The relay setting Z relay should be according to Equation (13):

$$Z_{\text{relay}} = \frac{5 \sin 75^\circ}{\sin 60^\circ \cdot \cos(60^\circ - 50^\circ)} = 5.65 \text{ ohms}$$

Or, referring to Table II (page 14), the relay actual setting should be:

$$\begin{aligned} S &= 1 \\ T &= 5.8 \\ M &= +.03 \end{aligned}$$

7.0 SETTING THE RELAY



Since the tap block screw for all "T" taps carries operating current, be sure that the screws are turned tight.

In order to avoid opening current transformer circuits when changing taps under load, the relay must be first removed from the case. Chassis operating shorting switches on the case will short the secondary of the current transformer. The taps should then be changed with the relay outside of the case and then reinserted into the case.

The KD-10 and KD-11 relays require settings for each of the three compensators (T , T_{AB} , and T_{BC}), each of the auto-transformers primaries (S , S_A , and S_C) and secondaries (M , M_A , and M_C). All of these

settings are made with the relay de-energized using taps on the tap plate located between the operating units. Figure 3 (page 36) shows the tap plate.

7.1 COMPENSATOR (T , T_{AB} AND T_{BC})

Each set of compensator taps terminate in inserts which are grouped on a socket and form approximately three quarters of a circle around a center insert which is the common connection for all of the taps. Electrical connections between common insert and tap inserts are made with a link that is held in place with two connector screws, one in the common and one in the tap. There are two T_B settings to be made since phase B current is passed through two compensators. A compensator tap setting is made by loosening the connector screw in the center. Remove the connector screw in the tap end of the link, swing the link around until it is in position over insert for the desired tap setting, replace the connector screw to bind the link to this insert, and retighten the connector screw in the center. Since the link and connector screws carry operating current, be sure that the screws are turned to bind snugly. Be careful not to overtighten these screws.

7.2 AUTO-TRANSFORMER PRIMARY (S , S_A , AND S_C)

Primary tap connections are made through a single lead for each transformer. The lead comes out of the tap plate through a small hole located just below or above the taps and is held in place on the tap by a connector screw (see Figure 3, page 36).

An "S" setting is made by removing the connector screw, placing the connector in position over the insert of the desired setting replacing and tightening the connector screw. The connector should never make electrical contact with more than one tap at a time.

7.3 AUTO-TRANSFORMER SECONDARY (M , M_A , AND M_C)

Secondary tap connections are made through two leads identified as L and R for each transformer. These leads come out of the tap plate each through a small hole, one on each side of the vertical row of "M" tap inserts. The lead connectors are held in place on the proper tap by connector screws.

Values for which an "M" setting can be made are from $-.18$ to $+.18$ in steps of $.03$. The value of a setting is the sum of the numbers that are crossed when going from the R lead position to the L lead position.

The sign of the “M” value is determined by which lead is in the higher position on the tap plate. The sign is positive (+) if the L lead is higher and negative (-) if the R lead is higher.

An “M” setting may be made in the following manner. Remove the connector screws so that the L and R leads are free. Determine from the Tables I to III the desired “M” value. Neither lead connector should make electrical contact with more than one tap at a time.

7.4 LINE ANGLE ADJUSTMENT

Maximum torque angle adjustment, if required, is accomplished by adjusting the compensator loading resistors P₃, P_{2A}, and P_{2C}. Refer to Section 13, Repair Calibration, for procedure.

7.5 INDICATING CONTACTOR SWITCH (ICS)

Connect the lead located in front of the tap block to the desired setting by means of the connecting screw. When the relay energizes a 125 or 250 volt dc type WL relay switch, or equivalent, use the 0.2 ampere tap; for 48 volt dc applications set the unit in a tap 2 and use a type WL relay with a S#304C209G01 coil, or equivalent. The relay is shipped set for 2.0 tap.

8.0 INSTALLATION

The relays should be mounted on switchboard panels or the equivalent in a location free from dirt, moisture, excessive vibration and heat. Mount the relay vertically by means of the mounting stud for the type FT projection case or by means of the four mounting holes on the flange for the semi-flush type FT case. Either the stud or the mounting screws may be utilized for grounding the relay. The electrical connections may be made directly to the terminals by means of screws for steel panel mounting or to the terminal stud furnished with the relay for thick panel mounting. The terminal stud may be easily removed or inserted by locking two nuts on the stud and then turning the proper nut with a wrench.

For detail information on the FT case refer to Instruction Leaflet 41-076. The relay contacts should stay open with panel de-energized.

9.0 EXTERNAL CONNECTIONS

Figure 19 (page 50) shows the connections for 3-zone protection utilizing the TD-4 timer. Figure 24 (page 53) is similar to Figure 19 except that the

TD-52 timer is used instead of the TD-4. Figure 20 (page 51) and Figure 21 (page 51) show the use of a 15/5 auxiliary current transformer so that the CT neutral may be formed elsewhere.

Ac connections for additional applications are shown in Figures 20 (page 51), 21 (page 51), 22 (page 52) and 23 (page 52). Three of these, Figures 20, 21, and 22 apply when the transmission line is terminated in a power transformer, and when low side voltage and current are used to energize the relays. In calculating the reach setting, the bank impedance must be added to the line impedance.

For the case of a wye-delta bank (Figures 21 and 22) the voltages and currents are phase-shifted by 30; however, this fact should be ignored, as the KD-10 and KD-11 relays are not affected by this phase-shift.

Figure 23 shows a KD-10 and TD-5 relay connected for generator back-up protection.

10.0 SWITCHBOARD TESTING

Immediately prior to placing the relay in service, the external wiring can be checked by manipulating the current and voltage applied to the relay. If such a check is desired, refer to Appendix A for the procedure.

10.1 CURRENT VOLTAGE RELAYS WITH MUTUAL REACTOR PRECAUTIONS

Relays which include compensators to modify the applied voltage (such as the KD types) will produce an output at their voltage terminals when the current circuits are energized.

Thus, it is possible to pull potential fuses and still have voltage appear on the relay side of the fuses. The magnitude of this voltage is dependent on magnitude of load or fault current, relay settings, relay impedance, and other potential circuit burden connected in parallel with the relay containing the compensator.

To avoid any difficulties due to interaction between current and voltage circuits, it is recommended that when PT fuses have been pulled to permit work on voltage circuits, that these circuits should not be considered safe until the current circuits have been de-energized, or until the voltage circuits have been shorted on the relay side of the fuses.

11.0 ACCEPTANCE TESTS

KD-10 and KD-11 relays have a very small number of moving parts which might become inoperative. Acceptance tests in general consist of:

- A visual inspection to make sure there are no loose connections, broken resistors, or broken resistor wires.
- An electrical test to make certain that the relay measures the balance point impedance accurately.

11.1 ELECTRICAL TESTS

An adjustable source of three-phase voltage and an adjustable single-phase current along with a means for varying the phase relation between current and voltage are required for testing the relay. The voltage source may be either "open delta", "closed delta", or "wye" connected. However, the relay operates only on delta quantities since it has no neutral connection.

Check electrical response of the relay using test connections shown in Figure 25 (page 54). Figure 26 (page 55) features the same connections except shows the use of additional switches that facilitate fast switchover from "phase-to-phase" fault mode to "three-phase" fault mode. Test connections, referred to in the test procedures, are the same on both drawings. Accuracy of the test results will depend to large degree on the accuracy of the instrumentation used. In general, it is advisable to restrict instrument readings to the last 20 percent of the scale. For most accurate phase angle readings use phase-shifter scale. This method requires calibration of the scale using accurate wattmeter (at 90°–0 watts and at 0°–maximum watts), or an accurate phase angle meter.

Make sure that correct lead-lag reference is established. Once the phase-shifter is calibrated, remove the wattmeter from the circuit. Make all phase angle reading from phase-shifter scale. This method eliminates the need for switching the current ranges in phase angle meter when used and results in superior accuracy. Always observe contact condition before current is applied. Closed contacts indicate reverse voltage sequence applied. Special attention should be paid to the phase-to-phase fault mode.

Testing may be done outside the case for convenience. All current readings include ± 6 percent tolerance. This tolerance includes ± 2.5 percent factory

tolerance and ± 3.5 percent allowance for total instrumentation error.

All phase angle settings are fault current lagging the $V_{PH1-PH2}$ voltage.

The impedance measured by the 3-phase unit in test 1 (Figure 26, page 55) is

$$Z_R = \frac{V_{L-L}}{1.73I_L} \quad [\text{Equ. 14}]$$

where V_{L-L} is the phase-to-phase voltage and I_L is the test current; similarly, in tests 5, 6 & 7 of Figure 26 the phase-to-phase unit measures.

$$Z_R = \frac{V_{L-L}}{2I_L} \quad [\text{Equ. 15}]$$

With phase-shifter set at maximum torque angle (θ_m).

$$I_{test}(3 \text{ phase}) = \frac{V_{L-L}}{1.73Z_R} \quad [\text{Equ. 16}]$$

$$I_{test}(\Theta - \Theta) = \frac{V_{LL}}{2Z_R} \quad [\text{Equ. 17}]$$

When testing the 3-phase unit, phase-shifter settings are always set for 30° higher than nominal maximum torque angle to account for test set-up where all angle measurements are made with reference to phase-to-phase and not phase-to-neutral quantities. The three phase unit maximum torque angle is always referenced to phase-to-neutral.

At any other angle α , relay reach is

$$Z = Z_\theta \cos(\theta_m - \alpha) \quad [\text{Equ. 18}]$$

where Z_θ = relay reach at maximum torque angle θ_m .

Test current I_α is calculated as

$$I_\alpha = \frac{I_{\theta_m}}{\cos(\theta_m - \alpha)}$$

$$I_{\theta_m} = \text{test current at } \theta_m \quad [\text{Equ. 19}]$$

Equation (19) should be used to predict test current when plotting impedance circle response of the relay.

The relay is set according to the following chart.

Table I:
RELAY SETTINGS FOR KD-10 & KD-11 RELAYS (.2 - 4.5 OHMS)

	S = 1							S = 2			S = 3		LEAD CONNECTION				
Δ T	.230	.307	.383	.537	.690	.920	1.23	.69	.920	1.23	.92	1.23	+M	-M	"L" Lead	"T" Lead	
	.195	.260	.325	.455	.585	.780	1.042	-	1.56	2.08	-	3.13	+18	-	.06	0	"L" OVER "R"
	.200	.267	.333	.467	.600	.800	1.070	-	1.60	2.14	-	3.21	+15	-	.06	.03	
	.205	.274	.342	.479	.616	.821	1.098	-	1.64	2.20	-	3.29	+12	-	.09	0	
	.211	.282	.351	.493	.633	.844	1.128	-	1.69	2.26	-	3.39	+09	-	.09	.03	
	.217	.290	.361	.507	.651	.868	1.160	-	1.74	2.32	-	3.48	+06	-	.06	.09	
	.223	.298	.372	.521	.670	.893	1.194	-	1.79	2.39	-	3.58	+03	-	.03	0	
	.230	.307	.383	.537	.690	.920	1.230	-	1.84	2.46	-	3.69	0	0	0	0	
	.237	.316	.395	.554	.711	.948	1.268	-	1.90	2.54	-	3.80	-	-03	0	.03	"R" OVER "L"
	.245	-	.407	.571	.734	.979	1.308	-	1.96	2.62	-	3.93	-	-06	.09	.06	
	.253	-	.421	-	.758	1.011	1.352	1.52	2.02	2.70	3.03	4.05	-	-09	.03	.09	
	-	-	.435	-	-	-	1.398	-	-	2.80	-	4.19	-	-12	0	.09	
	-	-	.451	-	-	-	1.447	-	-	2.89	-	4.34	-	-15	.03	.06	
	-	-	-	-	-	-	1.50	-	-	3.00	-	4.5	-	-18	0	.06	

Δ The tap plate values refer to standard maximum torque angle adjustment which is 75° for phase-to-phase unit and 60° for three phase unit.

Table II:
RELAY SETTINGS FOR KD-10 & KD-11 (0.75 - 21.2)

Δ T	S = 1							S = 2		S = 3		"M"		LEAD CONNECTION		
	.87	1.16	1.45	2.03	2.9	4.06	5.8	4.06	5.8	4.06	5.8	+M	-M	"L" Lead	"R" Lead	
	.737	.98	1.23	1.72	2.46	3.44	4.92	-	9.83	-	14.7	+18	-	.06	0	"L" OVER "R"
	.757	1.01	1.26	1.77	2.52	3.53	5.04	-	10.1	-	15.1	+15	-	.06	.03	
	.777	1.04	1.29	1.81	2.59	3.63	5.18	7.25	10.4	-	15.5	+12	-	.09	0	
	.798	1.06	1.33	1.86	2.66	3.72	5.32	7.45	10.6	-	16.0	+09	-	.09	.03	
	.821	1.09	1.37	1.91	2.74	3.83	5.47	7.66	10.9	-	16.4	+06	-	.06	.09	
	.845	1.13	1.41	1.97	2.82	3.94	5.63	7.88	11.3	-	16.9	+03	-	.03	0	
	.870	1.16	1.45	2.03	2.90	4.06	5.80	8.12	11.6	-	17.4	0	0	0	0	"R" OVER "L"
	.897	1.20	1.49	2.09	2.99	4.19	5.98	8.37	12.0	-	17.9	-	-03	0	.03	
	.926	-	1.54	2.16	3.09	4.32	6.17	8.64	12.3	-	18.5	-	-06	.09	.06	
	.956	-	1.59	2.23	3.19	4.46	6.37	8.92	12.7	-	19.1	-	-09	.03	.09	
	-	-	1.65	2.31	3.30	4.61	6.59	9.23	13.2	-	19.8	-	-12	0	.09	
	-	-	1.71	2.39	3.41	4.78	6.82	9.55	13.6	14.3	20.5	-	-15	.03	.06	
	-	-	-	-	-	-	7.07	-	14.14	-	21.2	-	-18	0	.06	

Δ The tap plate values refer to standard maximum torque angle adjustment which is 75° for both units.

**Table III:
RELAY SETTINGS FOR KD-10 & KD-11 RELAYS (1.3 - 36.6)**

Δ T	S = 1							S = 2		S = 3		"M"		LEAD CONNECTION		
	1.5	2.0	2.5	3.51	5.0	7.02	10.0	7.02	10	7.02	10	+M	-M			
	1.27	1.69	2.12	2.97	4.24	5.94	8.47	-	16.9		25.4	+18		.06	0	"L" OVER "R"
	1.30	1.74	2.17	3.05	4.35	6.10	8.70	-	17.4		26.1	+15		.06	.03	
	1.34	1.79	2.23	3.13	4.46	6.27	8.93	12.5	17.9		26.8	+12		.09	0	
	1.38	1.83	2.29	3.22	4.59	6.44	9.17	12.9	18.3		27.5	+09		.09	.03	
	1.42	1.89	2.36	3.31	4.72	6.62	9.43	13.2	18.9		28.3	+06		.06	.09	
	1.46	1.94	2.43	3.44	4.85	6.82	9.71	13.6	19.4		29.1	+03		.03	0	
	1.50	2.0	2.50	3.51	5.00	7.02	10.0	14.0	20.0		30.0	0	0	0	0	
	1.55	2.06	2.58	3.62	5.15	7.24	10.3	14.5	20.6		30.9	-	-03	0	.03	"R" OVER "L"
	1.60	-	2.66	3.73	5.32	7.47	10.6	14.9	21.3		31.9		-06	.09	.06	
	1.65	-	2.75	3.86	5.49	7.71	11.0	15.4	22.0		33.0		-09	.03	.09	
	-	-	2.84	3.99	5.68	7.98	11.4	16.0	22.7		34.1		-12	0	.09	
	-	-	2.94	4.13	5.88	8.26	11.8	16.5	23.5	24.8	35.3		-15	.03	.06	
	-	-	-	-	-	-	12.2		24.4		36.6		-18	0	.06	

Δ The tap plate values refer to standard maximum torque angle adjustment which is 75° for both units.

Relay Range	.2-4.5	.75-21.2	1.3-36.5
T, T _A , T _B , T _C	1.23	5.8	10.0
M, M _A , M _C	+1.15	+1.15	+1.15
S, S _A , S _C	1.0	1.0	1.0
Z ohms	1.07	5.04	8.7

If the relay is tested with other settings than specified in acceptance test use voltage levels specified here, except double the voltage specified for S = 2 settings and triple for S = 3 settings.

When testing KD-11 relays with other settings than specified here, refer to correction factors listed under Section 4.5, Distance Characteristic: KD-11, 3-phase Unit.

Use Equations (16) and (17), page 12, to estimate test current, and allow ±5 percent tolerance as explained above.

11.2 REVERSE REACH CHECK FOR KD-11 (.2 - 4.5 OHM RANGE ONLY)

Use voltage test connection #1 and set voltages V_{1F2F} = 50 volts V_{2F3F} = 2 volts: connect current lead “23” to “terminal 15, and current lead “22” to lead marked “21”. Set phase-shifter for current to lag V_{1F2F} voltage by 30° this current connection is equivalent to phase B current lagging V_{BN} voltage by 60° in the reverse directions. Adjust current for 3-phase unit to operate between 10.5 - 12.7 amperes.

Use Equations (16) and (17) to estimate test current, and allow 5 percent tolerance as explained above.

11.3 THREE-PHASE UNIT (LOWER UNIT)

A. Use test connections #1 of Figure 25 (page 54) and set V_{1F2F} = V_{1F3F} = 30 volts.

The current required to close contacts of the bottom unit should be:

Relay Range	.2-4.5	.75-21.2	1.3-36.6
Trip Current Amp	15.3-17.6	3.3-3.38	1.90-2.16
Δ Phase-Shifter set at	90°	105°	105°
Nominal Maximum Torque Angle θ _m	60°	75°	75°

Δ If maximum torque angle θ_m has been changed to a new angle, the new

$$I_t = \frac{I_t \sin \theta_m}{\sin \beta} \quad [\text{Equ. 20}]$$

then test relay at the new β – angle

11.4 PHASE-TO-PHASE UNIT (TOP UNIT)

A. Use test connection #5; set V_{F1F2} = 30 volts = V_{fault}.

Note that to set this voltage; set voltage V_{1-1F} = V_{2-2F}, first.

Make sure that,

$$V_{1-1F} = V_{2-2F} = \frac{V_{in} - V_{fault}}{2} \quad [\text{Equ. 21}]$$

Example 5

If V_{in} = 120
V_{fault} = 30

then V_{1-1F} = V_{2-2F} = $\frac{120 - 30}{2}$ = 45 volts,

trim up one of these voltages to set V_{FAULT} at exact value.

The current required to close contacts of the top unit should be:

Range	.2 - 4.5	.75 - 21.2	1.3 - 36.6
Δ Trip Current (I _t) amperes	13.3 - 14.7	2.85 - 3.15	1.63 - 1.80
Phase-Shifter Set Current Lagging V _{1F-2F}	75°	75°	75°

Δ If maximum torque angle, θ_m, has been changed to a new angle, use Equation (20) for trip current limits.

B. Repeat the test using test connections #6 and #7.

11.5 MAXIMUM TORQUE ANGLE TEST

If maximum torque angle test performance is desired follow instructions under Section 13, Calibration allowing ±5° tolerance. Observe the same voltage and current limits correction as mentioned above when relay is set for other settings than specified here. The test currents should be modified by following multiplier:

$$\frac{1.07}{Z} \text{ or } .2 - 4.5 \text{ ohm range}$$

$$\frac{5.03}{Z} \text{ or } .75 - 21.2 \text{ ohm range}$$

$$\frac{8.7}{Z} \text{ for } 1.3 - 36.6 \text{ ohm range}$$

11.6 INDICATING CONTACTOR SWITCH (ICS)

Close the main relay contacts and pass sufficient dc through the trip circuit to close the contacts of the ICS. The current should not be greater than the particular ICS tap setting being used for the 0.2 - 2.0 ampere ICS. The operation target should drop freely.

The contact gap should be approximately 0.047" between the bridging moving contact and the adjustable stationary contacts. The bridging moving contact should touch both stationary contacts simultaneously.

If the electrical response is outside the limits a more complete series of tests outlined in the Section 13, Repair Calibration may be performed to determine which component is faulty or out of calibration.

12.0 ROUTINE MAINTENANCE

The relays should be inspected periodically, at such time intervals as may be dictated by experience, to insure that the relays have retained their calibration and are in proper operating condition.

All contacts should be cleaned periodically. A contact burnisher #182A836H01 is recommended for this purpose. The use of abrasive material for cleaning contacts is not recommended because of the danger of embedding small particles on the face of the soft silver and thus impairing the contact.

See **Appendix B** (page 29) for additional information.

12.1 DISTANCES UNITS



Before making "hi-pot" tests, jumper all contacts together to avoid destroying arc suppressor capacitors.

For effective and quick maintenance it is advisable to repeat the acceptance test with the field settings. Then use portable test equipment such as the

K-DAR test set (I.L. 41-493.1) to record K-DAR test set dial readings. In the future all field tests can be made with the K-DAR test box just by referring to the previous dial readings without using more elaborate test set up of Figure 26 (page 55). When testing with S=2, double the test voltage. When testing with S=3, triple the test voltage. Note that KD-11 reach and maximum torque angle are increased with the lower T-settings (see Section 4.5, **DISTANCE CHARACTERISTICS: KD-11, 3-PHASE UNIT**, beginning on page 6).

12.2 INDICATOR CONTACTOR SWITCH (ICS)

Close the main relay contacts and pass sufficient dc current through the trip circuit to close the contacts of the ICS. The current should not be greater than the particular ICS tap setting being used for the 0.2-2.0 amperes ICS. The operation indicator target should drop freely.

13.0 REPAIR CALIBRATION

See **Appendix B** (page 29) for additional information and for trouble shooting limits.

Use the following procedure for calibrating the relay if the relay has been taken apart for repairs or the adjustments disturbed.

Connect the relay for testing as shown in Figure 25 (page 54). Figure 26 (page 55) shows a four-pole-double-throw switch in the test circuit that selects a phase-to-phase or a three-phase fault voltage condition, that will be applied to the relay voltage terminals. The rotary switch switches the fault voltage to various terminals and thereby simulates any phase combination of the phase-to-phase fault without the tester having to change connections or readjust the phase-shifter and variable auto-transformers.

For best results in checking calibration, the relay should be allowed to warm up for approximately one hour at rated voltage in a case. However, a cold relay will check to within three percent of the warm relay. The relay may be calibrated outside the case.

13.1 INITIAL SPRING SETTING

Set the moving contact spring adjuster so that the contact floats freely in the gap. Make sure that there is no friction which prevents free movement of the cylinder and contact arm.

13.2 SHAFT CLEARANCE

The upper pin bearing should be screwed down until there is approximately .025 inch (one complete turn of the screw) between it and the top of the shaft bearing. The upper pin bearing should then be securely locked in position with the lock nut. The lower bearing position is fixed and cannot be adjusted.

13.3 AUTO-TRANSFORMER CHECK

Auto-transformers may be checked for turns ratio polarity by using the No. 1 test connections of Figure 25 (page 54), and the procedure outline below.

Set S, S_A, and S_C on tap number 3. Set the “R” leads of M, M_A, M_C all on 0.0 and disconnected all the “L” leads. Adjust the voltages V_{1F2F} and V_{2F3F} for 90 volts. Measure the voltage from terminal 8 to the #1 tap of S and S_A. It should be 29.4 volts. From 8 to the #2 tap of S and S_A should be 58.6 volts. The voltage should read 29.4 volts from 8 to S_C = 1 and 58.6 volts from 8 to S_C = 2.

Set S, S_A, and S_C on 1 and adjust V_{1F2F} and V_{2F3F} for 100 volts. Measure the voltage drop from terminal 8 to each of the M and the M_A taps. This voltage should be equal to 100 (1 + the sum of values between R and the tap being measured). Example 100(1+.03+.09) = 112 volts.

Check the taps of M_C in the same manner. Transformer that have an output different from nominal by more than 1.0 volts probably have been damaged and should be replaced.

13.4 DISTANCE UNIT CALIBRATION

- a. Make the following relay settings:

Relay Range	.2 - 4.5	.75 - 21.2	1.27 - 36.6
T, T _A , T _B , T _B , T _C	1.23	5.8	10.0
M, M _A , M _C	+ .15	+ .15	+ .15
S, S _A , S _C	1.0	1.0	1.0

- b. Read Section 11.1, **ELECTRICAL TESTS** (page 12) and Section 12.1, **DISTANCE UNITS** (page 17), to become familiar with testing connections, instrumentation, and measurements. Use Figure 25 (page 54) or 26 for test connections.

14.0 THREE-PHASE UNIT (LOWER UNIT) P₃, CORE, & P_{3A} ADJUSTMENTS.

Use test connections #1 and set V_{2F1F} = V_{2F3F} = 25 volts. The current required for test should be:

Relay Range	.2 - 4.5	.75 - 21.2	1.3 - 36.6
Current	15.6	3.3	1.92
Phase-shifter Settings	60°	75°	75°
The Nominal M-T-Angle	60°	75°	75°

For others angles set test current according to Equation (12), page 9.

14.1 P₃ ADJUSTMENT

To check the P₃ adjustment, measure voltage across C_{3A}. Vary phase angle in both directions of the set value, to see that a low voltage across C_{3A} (below 1 volt) is obtained at the maximum torque angle setting. If minimum voltage is within 2 degrees, do not readjust. If the minimum voltage is obtained at some other angle readjust phase-shifting resistor or potentiometer (P₃) at the desired angle.

14.2 CORE ADJUSTMENT

For an initial adjustment of the core, restraint spring is to be set as above per Section 13.1, **INITIAL SPRING SETTING** (page 17). The relay should be preheated for at least one hour in the case with closed cover to compensate for effects of self-heating.

- a. Connect relay terminal 8 and 9 together, apply rated ac voltage between terminals 7 and 8. Adjust core by turning it slightly until the contact arm floats or restrains very slightly.
- b. **KD-10 ONLY:** Connect the relay terminals 7 and 8 together and apply rated ac voltage between 7 and 9. Adjust core until the contact arm just floats or restrains very slightly. If this is not possible, rotate core 90° and adjust. Recheck part “1” to determine if contact is floating or restraining. If not, repeat parts 1 and 2.

14.3 P_{3A} ADJUSTMENT

Remove current. Connect relay terminals 7 and 9 together and apply rated ac voltage between 7 and 8.

Adjust P3A so that the 3-ph unit contact just floats or restrains very slightly. If P3A does not have sufficient range to make this adjustment, use R3F resistor to bring P3A within the necessary range.

This calibration point is temperature sensitive and will change with time if capacitor C3C drifts. The relay contacts must stay open when terminals 7 and 9 are shorted and rated voltage is applied between terminals 7 and 8, with no current applied.

This test assures proper response of the 3-phase-unit for 3-phase faults and for CA phase-to-phase faults.

14.4 FINAL CORE ADJUSTMENT FOR KD-10 ONLY

This check is done to prevent contact closing on current-only.

- a. Short circuit relay terminals 7, 8 and 9 together.
- b. Pass 5 amperes in the current circuit in terminal 18 out terminal 19 increase the current to 30 amperes in convenient steps.
- c. Relay contacts should stay open. If contacts close, turn core further 90 degrees and repeat parts 1, 2 and 3 of Section 14.2, **CORE ADJUSTMENT** (page 18).
- d. The KD-11 relay is purposely biased to produce current-only contact-closing torque and will open its right hand contact at a current value of 3 amperes or less when T is on maximum tap.

(For .2-4.5 ohm range relay the current only operation will occur at $I_A = 5\angle 0^\circ$ amp and $I_B = 5\angle 120^\circ$ if two phase currents are available.)

14.5 MAXIMUM TORQUE ANGLE CHECK

- a. Use test connection #1.
- b. Adjust voltages V_{1F-2F} and V_{2F-3F} , and current as per table below:
- c. Check maximum torque angle using procedure described below:

Rotate the phase-shifter to find the angles, θ_1 and θ_2 , at which the bottom unit contacts just close. The maximum torque angle θ_m for the

three-phase-unit then is $\frac{(\theta_1 + \theta_2)}{2} - 30$ degrees.

The 30 degree correction is made to account for the fact that test set up angle measurements are

made with reference to phase-to-phase voltage instead of line-to-neutral voltages. The 3-phase-unit maximum torque is always referred to as phase-to-neutral.

Relay Range	0.2 - 4.5	.75 - 21.2	1.3 - 3.6
$V_{1F-2F} = V_{2F-3F}$	15	30	30
IT Test Current Δ	13	7	4
Adjust P_3 for Max. Torque angle, θ_m (Nominal if necessary)	60°	75°	75°

Δ Test current for other than nominal torque angle setting should be:

$$I_\theta = \frac{I_T \sin \theta_m}{\sin \beta} \quad [\text{Equ. 22}]$$

where β = new maximum torque angle.

Example 6

For $\theta_m = 75^\circ$, $I_{\text{test}} = 7$ amp.

if $\beta = 60^\circ$

$$\text{new } I_{\text{test}} = \frac{7 \times \sin 75^\circ}{\sin 60^\circ} = 7.8 \text{ amps}$$

Increasing P_3 value increases maximum torque angle, and, conversely, decreasing the P_3 value results in smaller angle.

For lower maximum torque angle adjustment below 70 degrees, for medium and long ranges, and for short range for settings below 55 degrees move red lead on fixed phase-shifting resistor R3, to the opposite terminal; where R3 is adjustable resistor use it in combination with P_3 setting without moving the lead.

14.6 CONTACT ADJUSTMENT

14.6.1 KD-10 Relay

With moving-contact arm against right-hand back-stop, screw the stationary contact in until it just touches the moving contact. (Check for contact by using an indicator lamp.) Then back the left-hand contact out two-thirds of the turn to give 0.020-inch gap between contacts.

14.6.2 KD-11 Relay

With moving-contact arm against right-hand side of the bridge, screw the right-hand contact in to just touch the moving contact and then continue for one more complete turn. Adjust left-hand contact as de-

scribed above, except back off one turn to give approximately 0.031 inch gap.

14.7 SPRING RESTRAINT

Reconnect for a three-phase fault, Test No. 1 and set the phase-shifter so that the current lags the voltage by:

90°	for .2 - 4.5 range
105°	for .75 - 21.2 and 1.27 - 36.6 ranges

Adjust the spring so that the current required to close the left-hand contact is as follows:

Relay Range	0.2 - 4.5	.75 - 21.2	1.3 - 36.6
$V_{1F-2F} = V_{1FV3F}$	2.5	10	10
I_{trip} KD-10	1.55- 1.65	1.22 - 1.28	.710 - .750
I_{trip} KD-11	1.55 - 1.65	1.22 - 1.30	.710 - .765

De-energized, the relay spring should open the contacts. Friction in the movement, relay not level, and electrostatic attraction may contribute to difficulties in adjusting this point. To avoid these difficulties it is recommended to level the relay properly, at this point omit light indicating circuit, and look for smooth contact action. Friction in bearings or dirt in cylinder will cause improper action.

14.8 IMPEDANCE CHECK

Use test connections #1 and set $V_{1F2F} = V_{2F3F} = 30$ volts. The current required to close contacts of the bottom unit should be:

Relay Range	.2 - 4.5	.75 - 21.2	1.3 - 36.6
Δ Trip Current	15.3 - 17.6	3.3 - 3.65	1.90 - 2.16
ϕ Phase-shifter set at	90°	105°	105°
The Nominal M-T-Angle	60°	75°	75°

ϕ Phase-shifter settings are always set for 30° higher than nominal maximum torque angle to account for phase difference between phase-to-phase and phase-to-neutral quantities. The 3 ϕ unit maximum torque angle is always referred to phase-to-neutral since it receives only one single-phase current.

Δ To determine the limits for current when the MTA, θ , is not equal to nominal maximum torque angle specified, multiply the nominal values tabulated above by the ratio $\frac{\sin \theta_m}{\sin \theta}$, where:

θ_m = original maximum torque angle
 θ = recalibrated maximum torque angle.

14.9 REVERSE REACH CHECK FOR KD-11 (.2 - 4.5 OHM RANGE ONLY)

Use voltage test connection #1 and set voltages $V_{1F2F}=50$ volts and $V_{2F3F}=2$ volts; connect current lead "23" to "terminal 15, and current lead "22" to lead marked "21". Let phase-shifter for current to lag V_{1F2F} voltage by 30° this current connection is equivalent to phase B current lagging V_{BN} voltage by 60° in the reverse directions. Adjust current for 3-phase unit to operate between 10.5–12.7 amperes.

15.0 PHASE-TO-PHASE UNIT (TOP UNIT): PHASE-TO-PHASE UNIT (T_{AB} AND T_{BC} COMPENSATORS) MAXIMUM SENSITIVITY ANGLE ADJUSTMENT

- Use #5 test connection for T_{AB} compensator, and #6 test connection for T_{BC} compensator.
- Measure voltage across C_{2A} for T_{AB} and across C_{2C} for T_{BC} adjustment.
- Set current and voltages equal to:

Relay Range	.2 - 4.5	.75 - 21.2	1.3 - 36.6
$V_{fault} = V_{1F-2F}$	30	30	30
Δ Trip Current (amps)	13.9	2.97	1.72
Phase-shifter set at current lagging V_{1F-2F} (θ_m)	75°	75°	75°

Δ For current limits when θ_m maximum torque angle, is not 75° multiply the values above $\frac{\sin 75}{\sin \beta}$ where β = new maximum torque angle for which the relay was recalibrated.

- Vary the phase angle in both directions of the set value, to see that a low voltage across C_{2A} (Test No. 5) or C_{2C} (Test No. 6) capacitor (below 1 volt) is obtained at the maximum torque angle setting. If within ±2 degrees, it can be left undisturbed. If the minimum voltage is obtained at some other angle, readjust phase-shifting resistor or potentiometer P_{2A} or P_{2C} at the desired angle.
- For core and reactor (X_{LAC}) adjustments, set restraint spring as above per Section 13.1, **INITIAL SPRING SETTING** (clockwise) , page 17.

- f. Connect terminals 7 and 8 together and apply rated ac voltage between terminals 8-9. Adjust core until contact arm floats in the middle of the gap. Use a screwdriver with insulated blade to avoid accidental contact with tap plate inserts. If contact arm does not float in the gap then rotate the core 90 degrees and readjust.
- g. Use test connection #5 Set $V_{1F-2F} = 2$ volts = V_{fault} . Note that to set this voltage you have to set voltages $V_{A-1F} = V_{B-2F}$ first where:

$$V_{A-1F} = V_{B-2F} = V_{in} - V_{2fault}$$

if $V_{in} = 120$ volts

$$V_{fault} = 2 \text{ volts}$$

$$V_{A-1F} = V_{B-2F} = \frac{120 - 2}{2} = 59 \text{ volts. Now trim up either voltage to get } V_{fault} = 2 \text{ volts.}$$

The current required to close contacts of the top unit should be:

Relay Range	.2 - 4.5	.75 - 21.2	1.3 - 36.6
Trip Current amperes	0.9 - 1.10	0.202 - 0.227	.115 - .135
Phase-shifter Set at current lagging	75°	75°	75°

With no current, relay contacts should stay open. If relay contacts are closed recheck voltage settings, incorrect voltage setting may result in negative sequence voltage phasing.

Set phase-shifter for maximum torque angle. Check pickup current. It should be within the limits specified above if not rotate core slightly until pickup current falls within specified range. Connect relay for 2-3 (Test No. 6) and recheck pickup. It should be within limits specified. For best trip calibration results adjust core so that trip current for Test No. 5 and No. 6 are equal.

Connect relay for Test No. 7. Check trip current. Use XLAC adjustable reactor to bring relay response within the specified limits. Moving red lead from front terminal to rear terminal or from rear terminal to front terminal of the reactor will reverse contact action of the unit. Screwing in or out the adjustable core should bring unit response within the limits. There

are three possible connections for reactor coils; series (loose coil termination leads connected together), parallel (each loose lead connected to the fixed terminals of the other coil), single front coil (omit loose lead of the rear coil from the circuit, bury it in insulation tubing). The reactor connections, should not require any changes unless some of the components of the phase-to-phase unit circuitry have been exchanged. Tighten up the locking nut when finished. If the unit does not operate within the specified limits, then rotate the cylinder unit core 90 degrees and repeat test numbers 5, 6, and 7.

15.1 MAXIMUM TORQUE ANGLE CHECK

- a. Use the No. 2 test switch position and lead connections. This connection is for checking the maximum torque angle of the TAB compensator. Set voltages and currents as per chart below.

Relay Range	0.2 - 4.5	.75 - 21.2	1.27 - 36.6
$V_{1F-2F} = V_{2FV3F}$	10	50	50
ΔI_{test} (amp)	12	10.0	6.0

Rotate the phase-shifter to find two angles θ_1 and θ_2 , at which the top unit contacts just close. The maximum torque angle θ for the phase-to-phase unit then is $\left(\frac{\theta_1 + \theta_2}{2} - 30\right)$ degrees. Do not allow more than ± 2 degrees error in this adjustment. Tighten the locking nut.

ΔI_{test} for other than nominal maximum torque angle, current should be:

$$I_{\theta} = \frac{I_T \sin \theta_m}{\sin \beta} \quad [\text{Equ. 23}]$$

Where θ_m = original maximum torque
 β = recalibrated maximum torque angle

Example 7

For $\theta_m = I_{test} = 10$ amps

For new $\beta = 60^\circ$

$$\text{New } I_{test} = \frac{10 \times \sin 75^\circ}{\sin 60^\circ} = 11.1 \text{ amps}$$

Increasing P2A or P2C value, rotation in clockwise direction maximum torque angle, and con-

versely, decreasing the P_{2A} or P_{2C} value results in smaller angles.

For lower maximum torque angle than 70 degrees move red lead on fixed phase-shifting resistor R_{2A} and R_{2C} to the opposite terminal. Where R_{2A} and R_{2C} are adjustable, use it in combination with P_{2A} and P_{2C} without moving the lead.

- b. Use the No. 4 test connection and repeat the procedure above for checking the T_{BC} compensator.

15.2 SPRING RESTRAINT

- a. Use test No. 1 connections except reverse the voltage phase sequence by interchanging the Brush connections so that Brush No. 1 is connected to 3F and Brush No. 2 is connected to 1F.
- b. Adjust the voltage V_{1F2F} and V_{2F3F} for 3.5 volts each with Brush No. 2 and Brush No. 1 respectively. Position the moving-contact spring adjuster so that the contact just floats and then return the circuit connections to normal with Brush No. 1 to 1F and Brush No. 2 to 3F. **De-energize the relay.** Spring should reset the contacts.

15.3 CONTACT ADJUSTMENT

The procedure for contact adjustment for the phase-to-phase unit is identical to that described for three-phase unit.

15.4 IMPEDANCE CHECK

Using the connections for Test Nos. 5, 6, and 7, set the phase-shifter so that the current lags voltage by θ_m . The current required to trip the phase-to-phase unit should be within the limits specified for each of the voltages. Note that for the phase-to-phase unit the impedance measured by the relay is

$$Z_R = \frac{V_{L-L}}{2I_L} \text{ where } V_{L-L} \text{ is phase-to-phase fault}$$

voltage and I_L is phase current.

The current required to close contacts of the top unit should be:

Relay Range	.2 - 4.5	.75 - 21.2	1.3 - 36.6
$V_{\text{fault}} = V_{1F-2F}$ (Volts)	30	30	30
Δ Trip Current (amps)	13.3 - 14.7	2.85 - 3.15	1.63 - 1.80
Phase-shifter Set at current lagging V_{1F-2F} (θ_m)	75°	75°	75°

Δ For current limits when θ_m maximum torque angle is not 75°, multiply the values above by $\frac{\sin 75}{\sin \beta}$ where β = new maximum torque angle for which the relay was calibrated.

For test voltages to be of correct sequence and values, use the following equation:

$$V_{1-1F} = V_{2-2F} = \frac{V_{in} - V_{\text{fault}}}{2} \quad [\text{Equ. 24}]$$

15.5 INDICATING CONTACTOR SWITCH (ICS)

Close the main relay contacts and pass-sufficient dc current through the trip circuit to close the contacts of the ICS. The current should not be greater than the particular ICS tap setting being used for the 0.2–2.0 ampere ICS. The operation indicator target should drop freely.

The contact gap should be approximately 0.047" for the 0.2/2.0 ampere unit between the bridging moving contact and the adjustable stationary contacts. The bridging moving contact should touch both stationary contacts simultaneously.

16.0 COMPENSATOR CHECK

Accuracy of the mutual impedance Z_C of the compensators is set within very close tolerances at the factory and should not change under normal conditions. The mutual impedance of the compensators can be checked with accurate instruments by the procedure outlined below.

- a. Set T , T_A , T_B , T_B , and T_C on the 1.23 tap for .2 - 4.5 range
5.80 tap for .75 - 21.2 range
10.0 tap for 1.3 - 36.6 range
- b. Disconnect the "L" leads of sections M, M_A , and M_C and the red-marked leads of R_3 , R_{2A} , and R_{2C} (with resistor loading removed $\theta = 90^\circ$).

- c. Connect terminals 12 to 14, 15 to 17, 16 to 18 and pass 10 amperes ac current in terminal 19 and out of terminal 13.
- d. Measure the compensator voltage V_C with a high resistance voltmeter (5,000 ohm/volt) as tabulated below. Refer to Figure 1 (page 35) for the location of R_3 , R_{2A} AND R_{2C} .

Measure V_C Between		Voltmeter Reading
Lead	and Fixed End of	
"L" of M	R3	$V_C = 1.5 IT \left(\frac{\sin \theta}{\sin 75^\circ} \right) \Delta$
"L" of M_A	R2A	$V_C = 2 IT \left(\frac{\sin \theta}{\sin 75^\circ} \right)$
"L" of M_C	R2C	

Δ Use $\sin 60^\circ$ for .2 - 4.5 range

Example 8

For .75 - 21 ohm range $T = 5.8$ relay 3-phase compensator will read $V_C = 90.1$ volts and for phase-to-phase compensators where $T=5.8$ the voltages are:

$V_C = 120$ volts (phase A)
 $V_C = 120$ volts (phase C)

Accuracy of the measurement will depend on the instrumentation used. Factory adjusted compensator is within $\pm 0.5\%$ on maximum tap and $\pm 1\%$ on all other taps. A realistic tolerance should be allowed for accuracy of the primary current measurement, and the accuracy of the voltmeter to be used to arrive at what is a "good" compensator. A zero voltage reading may be caused by open potentiometer or compensator.

Additional measurements on the compensator can be made to check the compensator tap sequence,

and to check on the condition of all (except terminals 8-9-circuit of the 3-phase unit) relay circuits.

With relay energized with 120 Vac only, and all S-settings set = 1, and $M = +15$, check voltage drops starting at the minimum tap and each successive "T" tap. Voltage readings will start at the millivolt level, and increase with successive tap values. Erratic voltage reading will indicate open tap. These type of readings could be taken at any relay setting except when comparing any two relays, or readings from the same relay at different times it should be clear that relay settings for which measurements are taken should be identical. The table below gives typical readings for settings specified above. Use this table as a guide only.

0.2 - 4.5 Ohms Range	
T_A, T_B, T_B, T_C	T
.003 - .006	.008 - .016
.008 - .011	.018 - .031
.017 - .021	.004 - .063
.026 - .031	.006 - .088
.040 - .047	.100 - .138
.060 - .068	.145 - .210
.75 - 21.2 Ohms Range	
T_A, T_B, T_B, T_C	T
.015 - .026	.033 - .050
.032 - .054	.072 - .092
.072 - .110	.145 - .190
.125 - .190	.260 - .190
.200 - .290	.400 - .340
.295 - .470	.645 - .800
1.3 - 36.6 Ohms Range	
T_A, T_B, T_B, T_C	T
.038 - .052	.055 - .070
.080 - .100	.105 - .150
.150 - .200	.220 - .300
.290 - .340	.390 - .540
.450 - .535	.600 - .850
.700 - .860	.950 - 1.30

THIS PAGE RESERVED FOR NOTES

APPENDIX A

SWITCHBOARD TESTING WITH KD-10 AND KD-11 RELAYS

External connections may be checked at the relay provided there is sufficient load current flow at a known power factor angle. Relay current should be at least $\frac{7}{T}$ amperes (1.2 amps when $T = 5.8$). This check is appropriate prior to commissioning the relay or when trouble shooting.

1.0 POTENTIAL CIRCUIT CHECK

Close the three relay potential switches numbered 7, 8, and 9, (Figure 19). The connection for the proper phase sequence will be indicated by a strong contact-opening torque. Closing torque will indicate reverse-phase sequence.

2.0 CURRENT VERIFICATION

To verify the proper current connections use the following procedure:

- a. Set $T = 5.8$, $S = 1$ for maximum sensitivity. (Lower or higher taps may be used, provided currents exceeds $\frac{7}{T}$). Open current switches first for safety.
- b. Read watts, vars and amperes.
- c. Plot watts and vars on the diagram in Figure 27. Draw a line at the load angle determined by this plot. Designate this line as I_{REF} . See Figure 28 for example.
- d. Perform the nine switching combinations in Table IV (page 26), recording the relay contact position for each combination. Actually only 6 combinations are needed to verify the currents, so that any group of three need not be used. This is important where the load angle falls too close to the zero torque line. If the indicated power-factor angle is within 3° of the test limit for any group of three tests, these should be ignored.
- e. Verify the currents using the procedure illustrated in Table V (page 27). Here the "correct contact position" is determined by observing whether the I_{REF} line in figure 28 intersects the solid or the dashed part of circle. (For example, test 1b

shows a solid circle indicating that the contact should close.) Next compare the actual contact positions to the correct ones.

- f. If the contact positions are proper, the current connections are correct and the test is complete, otherwise proceed to identify the currents using the following procedure.

3.0 CURRENT IDENTIFICATION

If the verification check discloses incorrect current connections, the following procedure may be used to determine what is wrong. However, if one set of three switching combinations places the relay too close to the zero-torque line, use conventional techniques, instead, since identification requires all nine switching combinations.

- a. Plot aI_{REF} and a^2I_{REF} at 120° angles from I_{REF} . See Figure 28 for example. These currents are related to the phase currents as shown in the following table:

Phase Receiving Current	I_{REF}	a^2I_{REF}	aI_{REF}
1	$I_{PH.A}$	$I_{PH.B}$	$I_{PH.C}$
2	$I_{PH.B}$	$I_{PH.C}$	$I_{PH.A}$
3	$I_{PH.C}$	$I_{PH.A}$	$I_{PH.B}$

- b. Prepare Table VI (page 27) similar to Table V (page 27) using Figure 28 (page 56). For example, for test 1b the contacts were open. Such a result would occur if I_{REF} of the wrong polarity is actually flowing in the phase A circuits of the relay. This conclusion is drawn by noting that I_{REF} in Figure 28 intersects the solid part of the test 1b circle. This says that if $+I_{REF}$ is flowing the contacts would close. Since the contacts actually open, then $-I_{REF}$ could be flowing. similarly, for test 1b, $-a^2I_{REF}$ could be flowing, since the a^2I_{REF} line also intersects the solid part of the test 1b

circle. By the process of elimination for each set of 3 tests, the actual current is identified. For example, in Table V (page 27), phase A receives $-I_{PH,A}$ whereas $+I_{PH,A}$ should be flowing. In phase B $+I_{PH,C}$ is flowing as shown in Figure 29. To extract this bit of information from Table V (page 27), use the above table relating the phase currents to I_{REF} , a^2I_{REF} .

NOTE: In Table V that a^2I_{REF} is flowing in the phase B circuits of the relay. The above table shows for this set of 3 tests that a $a^2I_{REF} = I_{PH,C}$.

- c. Correct the external connections and then verify the currents.

Table IV:

SWITCHING COMBINATION	SWITCHING FOR CURRENT VERIFICATION AND IDENTIFICATION									
	Position of Switches Numbered:							Unit Which Should be Observed	Phase Receiving Current	
	Voltage Switch			Current Switch (Blank indicates open switch)						
	V_{AN} 7	V_{BN} 8	V_{CN} 9	I_A 12, 13	I_B 14, 15	I_C 16, 17	I_A 18, 19 (3 ϕ)			
1	Open & jump sw. jaw to 9	Closed	Closed	a			Closed		ϕ - ϕ & †	C
				b	‡ Closed			Closed		ϕ - ϕ & 3 ϕ
2	Closed	Open & jump sw. jaw to 7	Closed	a	Closed			Closed	ϕ - ϕ & 3 ϕ	A
				b		Closed				ϕ - ϕ & †
3	Closed	Closed	Open & jump sw. jaw to 8	a		Closed			ϕ - ϕ & †	B
				b			Closed			ϕ - ϕ & †
4	Closed	Closed	Open & jump sw. jaw to 7	‡ Closed				Closed	ϕ - ϕ & 3 ϕ	A
5	Open & jump sw. jaw to 8	Closed	Closed			Closed			ϕ - ϕ & †	B
6	Closed	Open & jump sw. jaw to 9	Closed				Closed		ϕ - ϕ & †	C

† Block 3 ϕ Unit Open.
‡ If current is over 5 amps.

**Table V:
VERIFICATION EXAMPLE USING ASSUMED LOADING OF FIGURE 29**

PHASE TO BE VERIFIED	SWITCHING COMBINATION	CORRECT CONTACT POSITION	ACTUAL CONTACT POSITION	
			IF WIRING IS CORRECT	EXAMPLE WITH INCORRECT WIRING
A	1b	C	C	O
	2a	C	C	O
	4	O	O	C
B	2b	C	C	C
	3a	C	C	O
	5	O	O	C
C	3b	C	C	O
	1a	C	C	O
	6	O	O	O

**Table VI:
IDENTIFICATION EXAMPLE USING ASSUMED LOADING OF FIGURE 29**

I _{REF} PHASE RECEIVING CURRENT	SWITCHING COMBINATION	EXAMPLE OF CONTACT POSITION	CURRENT & POLARITY WHICH CAN PRODUCE OBSERVED CONTACT POSITION		
			I _{REF}	a ² I _{REF}	aI _{REF}
A	1b	O	-	-	+
	2a	O	-	+	+
	4	C	-	+	-
B	2b	C	+	+	-
	3a	O	-	+	+
	5	C	-	+	-
C	3b	O	-	-	+
	1a	O	-	+	+
	6	O	+	-	+

THIS SPACE RESERVED FOR NOTES

APPENDIX B

THE KD COMPENSATOR DISTANCE RELAYS CALIBRATION AND MAINTENANCE PROCEDURES

A calibration and maintenance program should involve two steps: 1) a receiving acceptance check and 2) a routine (periodic) maintenance program. These two steps are outlined below.

1.0 RECEIVING ACCEPTANCE

Received relays should be subjected to the checks outline in the applicable I.L. These checks will insure that there is no shipping damage and the relay has been received in the same calibrated condition as it left the factory. They will insure that set-up procedures such as removing contact blocking has been accomplished. A receiving acceptance check should include the following steps:

- a. Perform all of the mechanical and electrical tests listed in the receiving acceptance section of the applicable I.L., include the maximum torque angle test, even if it is not called for in some I.L.'s.
- b. Follow the appropriate test procedures outlined in Instruction Leaflets covering the KDAR Field Test Unit. It is suggested that all dial test readings in each test be recorded for future reference. This information will be very helpful in recognizing possible drift or electrical characteristics.
- c. If the settings to be applied to the relay when it is installed are known, the relay should be set to these settings and checked with the field units as noted in step 2 above. A record for future reference should be taken. The relay test values using the KDAR test unit should check to be within ± 7 percent of the relay settings.

2.0 ROUTINE MAINTENANCE

The relay should be checked periodically at time intervals dictated by previous experience and practices. ABB recommends the time interval between checks be a maximum of two years. Routine maintenance should include at least the following steps.

- a. Repeat step 2 and 3 under **RECEIVING ACCEPTANCE** and record test results.
- b. Compare test results with previous results. If any test values deviate from previous checks by

more than 5 percent, recheck relay performance in line with the receiving acceptance checks outlined above step 1.

- c. Retain records of test results on each particular relay. During each routine maintenance, the records should be analyzed to determine if there is any evidence of drift; i.e., continued change in characteristic in the same direction. Evidence of drift should be traced to the particular element involved, usually a capacitor or resistor and this element replaced.
- d. Some of the more common component problems may be detected as follows:

With the relay mounted on a panel and energized by station C, T's & P. T's open all trip circuits and all current switch positions 12, 13, 14, 15, 16, 17, 18, 19, and phase C voltage switches (terminal 9), and if applicable, an additional switch position on the separately energized 3 ϕ unit. Check the internal schematic for your particular relay. Jumper terminal 7 to terminal 9 and to any other applicable switch normally connected to phase C, on the relay side (upper half of the switch). The contacts of both operating units should stay open. If the 3-phase unit contact closes, it indicates misadjustment of resistor, R_{3A}, or potentiometer, P_{3A} (most common cause), or defective capacitor, C_{3C}. Follow the instructions for trouble shooting in Section 3.3. **"SUGGESTED PROCEDURE FOR DETECTING AND REPLACING DEFECTIVE C_{3C} CAPACITOR FOR KD-4, KD-5 AND KD-10 RELAYS"** (page 31), and the proper instruction leaflet for KD/KD-1, and KD-10/KD-11 relays.

If phase-to-phase unit closes, recheck for:

- KD/KD-1 relays R_{MA} & R_{MC}-Calibration
- KD-4/KD-41 & KD-5 R_{AC}-Calibration
- KD-10/KD-11 X_{LAC}-Adjustment

3.0 CALIBRATION AND TROUBLESHOOTING HINTS

3.1 CALIBRATION OF THE RELAY FOR MAXIMUM TORQUE ANGLE

Experience has shown that calibration of the relay for maximum torque angle is the procedure most susceptible to error. Two potential sources of error most common are:

- a. Instrumentation errors: Be sure of the accuracy of calibration of all instruments and phase-shifters used. Instruments should be chosen and ranges selected so that readings are taken with the instrument reading in the top third of the scale.

When a phase-shifter is used, attention should be paid to voltage and current settings that change as the angle is varied. To avoid inaccuracies due to this effect, check the voltage and current settings when contact operation indicates that maximum torque angle check point has been reached.

- b. Failure or miscalibration of components not connected with angle adjustment: To distinguish between the two sources of error it is recommended a compensator nulling test be performed as follows.

3.1.1 KD-4, 41, 5, 10, and 11 Relays: Phase-to-Phase Unit (T_{AB} and T_{BC} Compensators) Maximum Sensitivity Angle

- a. Use "PH-PH-1-2 Phase" test connection for T_{AB} compensator, and "PH-PH-2-3" test connection for T_{BC} compensator. Refer to Figure 26 (page 55).
- b. Measure voltage across C_{2A} for T_{AB} and across C_{2C} for T_{BC} .

- c. Set current equal to:
$$\frac{V_{1F2F}}{2X \text{ Relay Setting}}$$

The current should be high enough to provide an accurate phase angle meter reading, or any convenient value if a phase-shifter is used for direct angle reading.

- d. Set the phase-shifter for the desired maximum torque angle value. NOTE THE VOLTAGE.
- e. Vary the phase angle in both directions of the set value, to see that a low voltage (below one volt) is obtained at the maximum torque angle set-

ting. If within two degrees, it can be left undisturbed. If minimum voltage is obtained at some other angle, readjust phase-shifting resistor or potentiometer at the desired angle.

3.1.2 KD and KD-1 Relays: Phase-to-Phase Unit (T_{AB} and T_{BC} Compensators) Maximum Sensitivity Angle

Follow procedure above except:

- a. For T_A compensator, use connection #2, omit voltage connection to terminal 9, disconnect L_A -lead, insert voltmeter to measure open circuit voltage and use twice the current value obtained for KD-10 tests. Follow procedure outline above except adjust R_{2A} when required.
- b. For T_B compensator, use procedure outline above, except use #3 connection and adjust R_{2B} when required.
- c. For T_C compensator, use connection #4, omit voltage connection to terminal 7, disconnect L_C -lead, and adjust R_{2C} when required as per part 1.

3.2 THREE-PHASE UNIT: (T COMPENSATOR OF ALL KD TYPE RELAYS)

- a. Use connection #1.
- b. Measure voltage across $C3A$.
- c. Set the current equal to:
$$\frac{V_{1F2F}}{1.5 \text{ Relay Setting}}$$

The current should be high enough to provide an accurate phase meter reading, or any convenient value if a phase-shifter is used for direct angle reading.

- d. Set the phase-shifter for the desired maximum torque angle value.
- e. Vary phase angle in both directions of the set value, to see that a low voltage (below 1 volt) is obtained at the maximum torque angle setting. If minimum voltage is within 2 degrees, do not readjust. If the minimum voltage is obtained at some other angle readjust phase-shifting resistor or potentiometer at the desired angle.

3.3 SUGGESTED PROCEDURE FOR DETECTING AND REPLACING DEFECTIVE C_{3C} CAPACITOR FOR KD-4, KD-5 AND KD-10 RELAYS

Step 1

Set S = 1 for the 3-phase unit.

Apply approximately 120 volts to relay terminal 7 and 8 and short-out terminals 7 and 9 (for KD-5 between terminals 6 and 9 and some short reach KD-4).

If contacts of the 3-phase unit close, then the C_{3C} capacitor is under suspicion, but improperly adjusted R_{3A} can be suspected as well.

Step 2

Remove the connections made in Step 1.

Apply approximately 120 volts (i.e., 100-130 volts) to terminals 8 and 9 = V₈₉.

Measure the voltage across the C_{3C} capacitor with a high impedance voltmeter - 5000 ohms/volt.

For .75 – 20 ohms reach KD-4 relays, the minimum voltage should be $V_{\min} = 3.5 \times V_{89}$. If V_{\min} is less than $3.85 \times V_{89}$ then replace C_{3C}.

For .2 – 4.35 ohms reach KD-4 and KD-5 the minimum voltage should be $V_{\min} = 2.82 \times V_{89}$. If V_{\min} is less than $2.82 \times V_{89}$ then replace C_{3C}.

For all ranges KD-10 use same procedure as for .75 – 20 ohm reach.

Step 3

Relays which fail step 1, or have C_{3C} capacitor replaced after failing step 2, or after C_{3A} capacitor is replaced, will require readjustment of R_{3A} or P_{3A}. Repeat step 1 and adjust R_{3A} or P_{3A} so that contacts just open.

Omit this procedure for KD-10 relays.

- a. For .75 – 20 ohm reach KD-4 relays:
When the relay is **preheated** as per Instruction Leaflet, decrease R_{3A} setting by 10% of total R_{3F} and R_{3A} resistance.

OR

For a **cold** relay repeat step 1 and adjust R_{3A} so the contact just opens. No further adjustment is required.

- b. For .2 – 4.35 ohm reach KD-4 relays with sub "A" in style number.

If the relay is **cold**, decrease R_{3A} setting 8% of total R_{3A} + R_{3F} resistance.

If the relay is **hot**, decrease R_{3A} setting 5% of total R_{3A} + R_{3F} resistance.

- c. For .2 – 4.35 ohm relays without sub "A" in style number.

If the relay is **cold**, decrease R_{3A} setting 7% of total R_{3A} + R_{3F} resistance.

If the relay is **hot**, decrease R_{3A} setting 4% of total R_{3A} + R_{3F} resistance.

NOTE: R_{3A} range of adjustment may occasionally be insufficient. If so, set R_{3F} for maximum resistance, or replace R_{3F} resistor with higher value.

- d. For KD-10 follow Instruction Leaflet to adjust R_{3A} or P_{3A}.

- e. Suggested procedure for C_{3C} for KD-1, KD-41, KD-11 relays:

1) No voltage test is required across the C_{3C} capacitor.

2) If C_{3C} has been found bad (shorted or leaky) repeat P_{3A} or R_{3A} adjustment above.

3.4 SUGGESTED PROCEDURE FOR REPLACEMENT OF C_{2C}, C_{2A} CAPACITORS

After the capacitors have been replaced:

- a. Open relay switch 9 (phase C potential).
- b. Short terminals 7 and 9 on relay side and apply approximately 120 volts to terminals 7 and 8.
- c. Adjust R_{CA} resistor for KD-4-41 relays and XL_{AC} for KD-10-11 relays so contact just floats, favoring contact opening direction.
- d. If desired, repeat 2.5 volts calibration point.
- e. For KD and KD-1 relays, follow procedure for R_{MA} and R_{MC} calibration.

Reserved for Notes

APPENDIX C

LIST OF PHOTOS, DRAWINGS and CURVES

1. Type KD-10 Relay Chassis--Front and Back- - - - -Photo - - - - -page 35

2. Compensator Construction - - - - - 849A034 - - - - -page 36

3. Typical Tap Plate- - - - -Photo - - - - -page 36

4a. Internal Schematic of KD-10 Relay (.25-4.5 Ohm Range) - - - - - 3490A81 - - - - -page 37

4b. Internal Schematic of KD-11 Relay (.2-4.55 Ohm Range) - - - - - 3512A02 - - - - -page 37

5a. Internal Schematic of KD-10 Relay (.75-21.0 Ohm Range) - - - - - 3507A70 - - - - -page 38

5b. Internal Schematic of KD-11 Relay (.75-21.0 Ohm Range) - - - - - 3490A82 - - - - -page 38

6. Internal Schematic of KD-10 Relay (1.3-36.0 Ohm Range) - - - - - 880A988 - - - - -page 39

7. Internal Schematic of KD-11 Relay (1.3-36.0 Ohm Range) - - - - - 880A989 - - - - -page 39

8. Voltage and Current Conditions for the Three-Phase Unit at the Shaded Breaker for Three-Phase Faults at Various Locations - - - - 407C459 - - - - -page 40

9. Voltage and Current Conditions for the Phase-to-Phase Unit at the Shaded Breaker for B-C Faults at Various Locations - - - - - 408C161 - - - - -page 41

10. Impedance Circles for Phase-to-Phase Unit in the Type KD-10 and KD-11 Relay - - - - - 849A040 - - - - -page 42

11. Impedance Circle for Three-Phase Unit in the Type KD-10 Relay - - - - 849A035 - - - - -page 42

12. Impedance Curves for KD-10 Relay- - - - - 188A295 & 762A684 - - - - -page 42

13. Impedance Circle for Three-Phase Unit in Type KD-11 Relay - - - - - 185A346 - - - - -page 43

14. Typical Operating Time Curves Normal Voltages Before Fault 120 Volts, Phase-to-Phase Unit - - - - - Curve 619487, Curve 762A685, Curve 619465 - - - - -page 44

15. Typical Operating Time Curves for KD-11 Phase-to-Phase Unit - - - - - 762A686 - - - - -page 45

16. Typical Operating Time Curves of Type KD-11 Relay Three-Phase Unit (.75-20 Ohms)- - - - - 762A687 - - - - -page 45

17a. Type KD-10 Burden Curves - - - - - 1426C53 - - - - -page 46

17b. Type KD-10 Burden Curves - - - - - 1426C54 - - - - -page 47

18a. Type KD-11 Burden Curves - - - - - 1426C55 - - - - -page 48

18b. Type KD-11 Burden Curves - - - - - 1426C52 - - - - -page 49

19. External Schematic--Two KD-10 Relays, One KD-11, and a Type KD-4 Timing Relay - - - - - 265C199 - - - - -page 50

20.	External Schematic–Two KD-10 Relays, One KD-11 Relay, Auto-transformer Termination - - - - -	774B144 - - - - -	-page 51
21.	External Schematic–Two KD-10 Relays, One KD-11 Relay, Wye-Delta Bank Termination with Grounded Wye on Relay side - - - - -	774B143 - - - - -	-page 51
22.	External Schematic–Two Type KD-10 Relays, One KD-11 Relay, Wye-Delta Bank Termination with Delta on Relay Side - - - - -	774B142 - - - - -	-page 52
23.	External Schematic–Type KD-11 Relay with Type TD-5 Timing Relay for Generator Back Up Protection - - - - -	774B141 - - - - -	-page 52
24.	External Schematic–Two Type KD-10 Relays, One Type KD-11 with TD-52 Timing Relay - - - - -	265C201 - - - - -	-page 53
25.	Basic Test Connections for Type KD-10 and KD-11 Relays - - - - -	774B375 - - - - -	-page 54
26.	Test Connections for Type KD-10 and KD-11 Relays Using Auxiliary Switches - - - - -	774B821 - - - - -	-page 55
27.	Phase Diagram for Current Circuit Verification and Identification - - - - -	185A016 - - - - -	-page 56
28.	Phase Diagram Showing Assumed Load Conditions - - - - -	9655A41 - - - - -	-page 56
29.	Actual Wiring for the Assumed Test Results - - - - -	762A630 - - - - -	-page 56
30.	Outline and Drilling Plan for KD-10 and KD-11 in FT-42 Case - - - - -	57D7905 - - - - -	-page 60

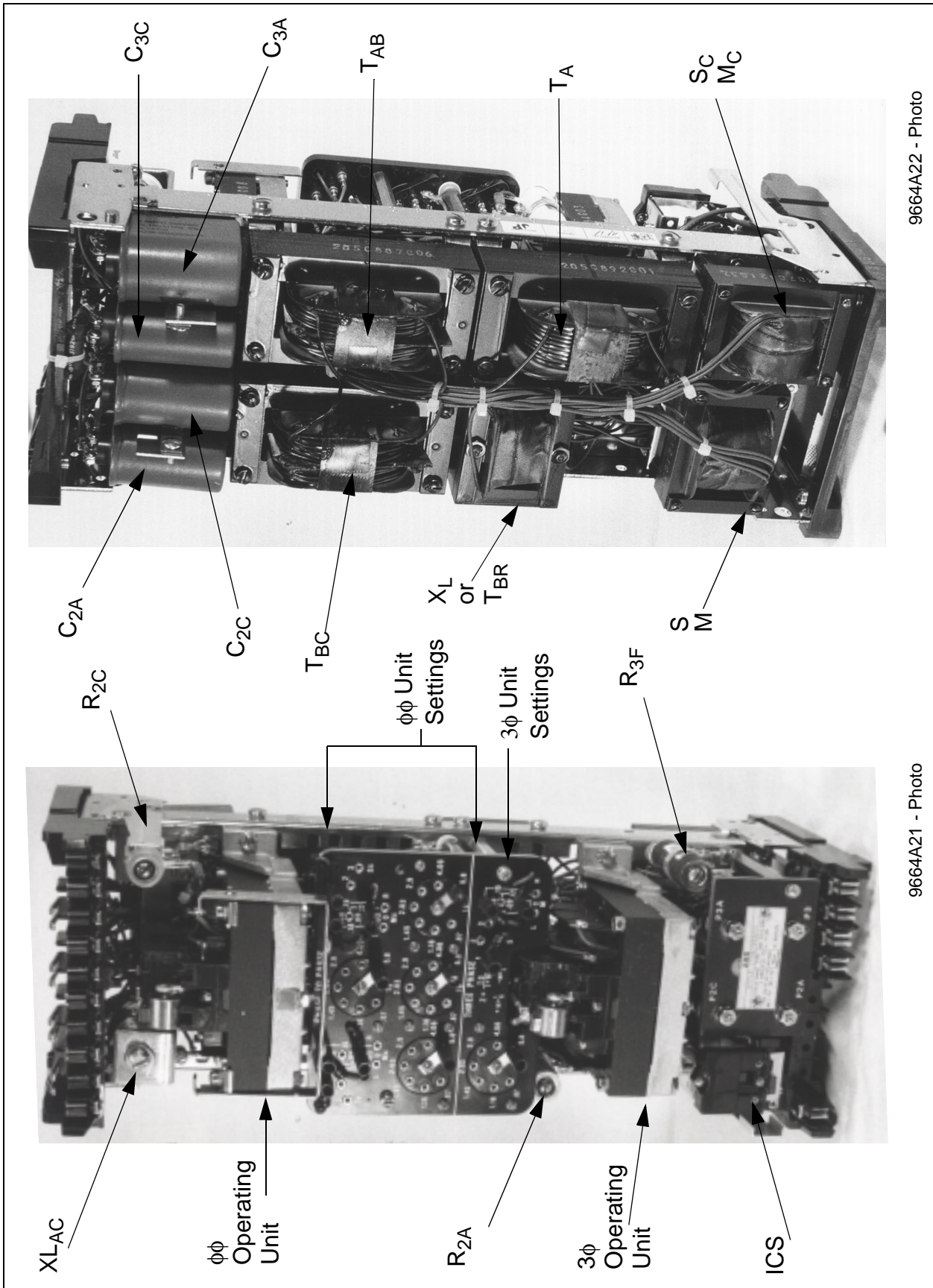

9664A22 - Photo

9664A21 - Photo

Figure 1: Type KD-10 Relay Chassis

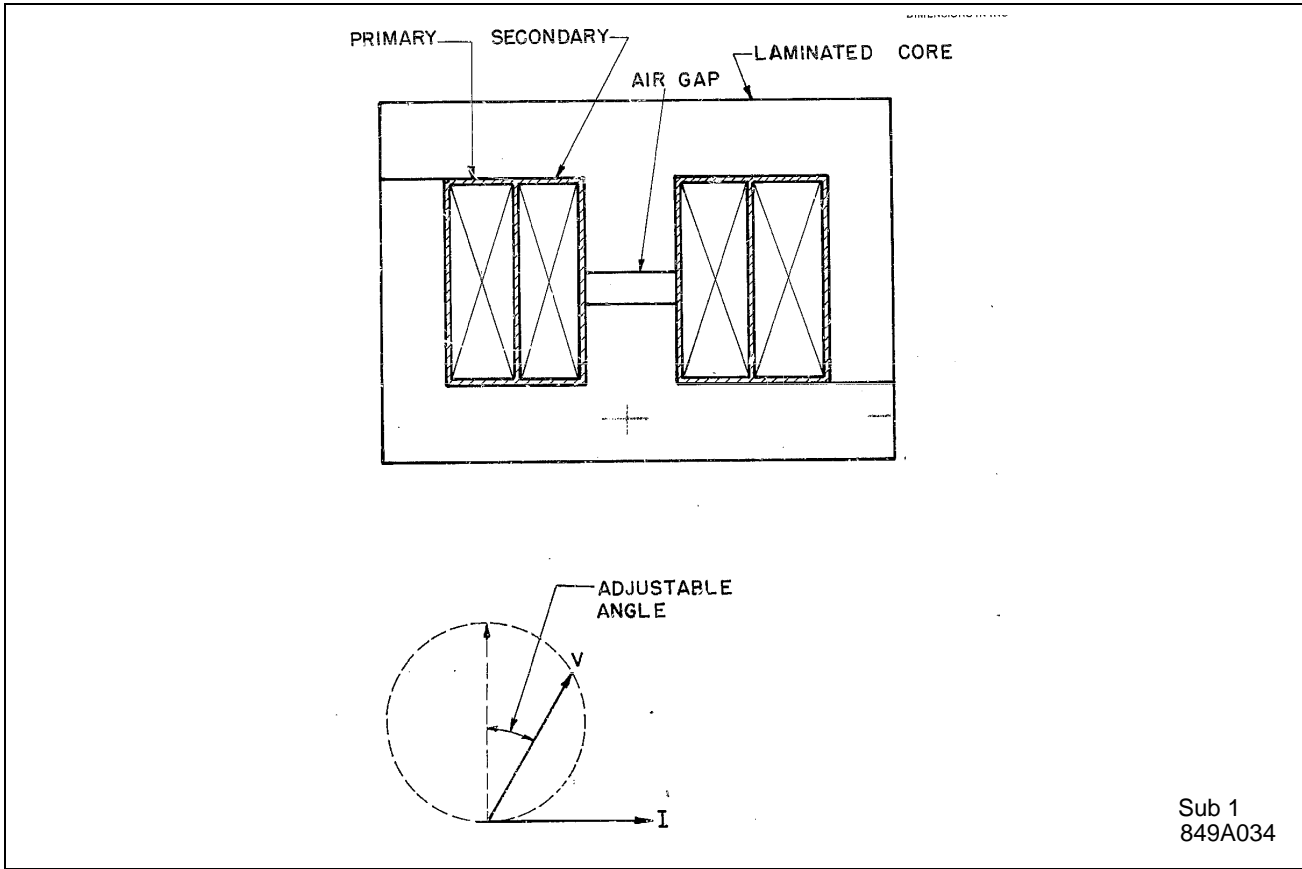

Sub 1
849A034

Figure 2: Compensator Construction

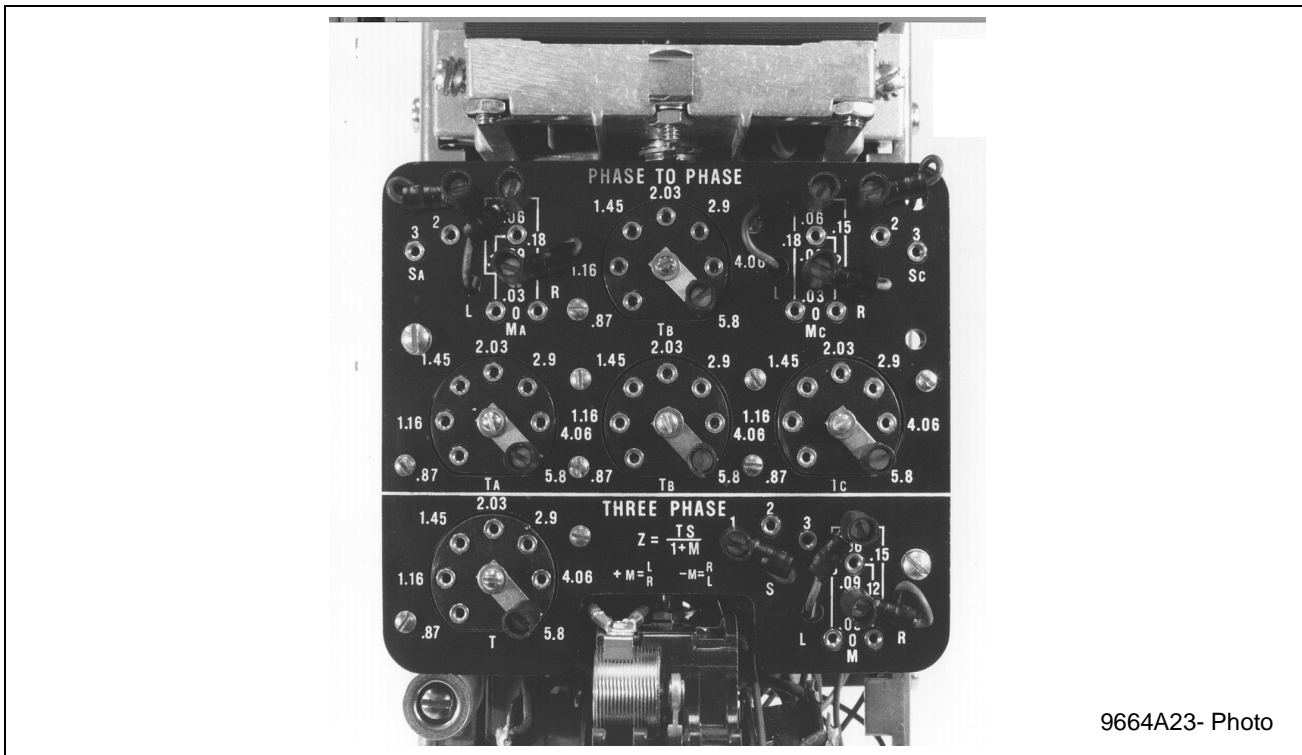

9664A23- Photo

Figure 3: Typical Tap Plate

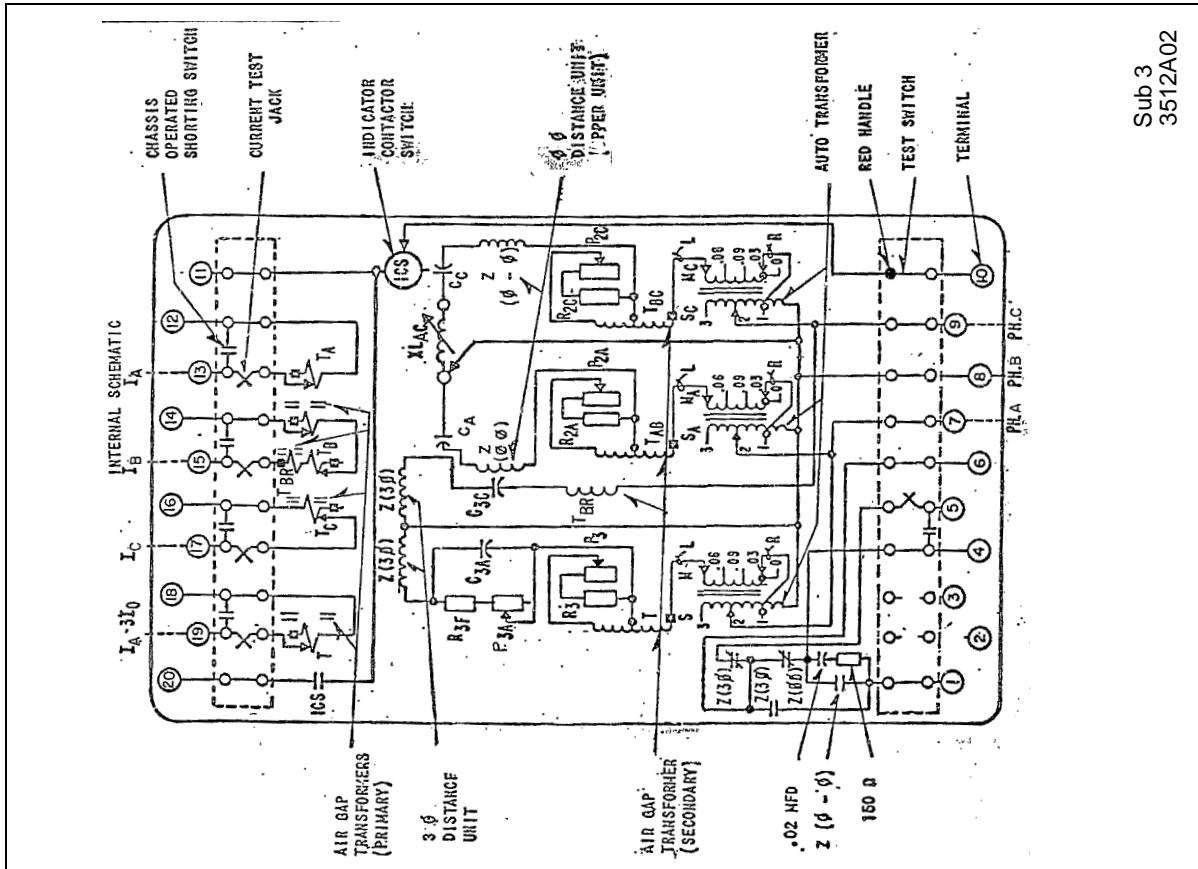

Sub 3
3512A02

Figure 4b: Internal Schematic of KD-10 Relay (.2-4.55 Ohm Range)

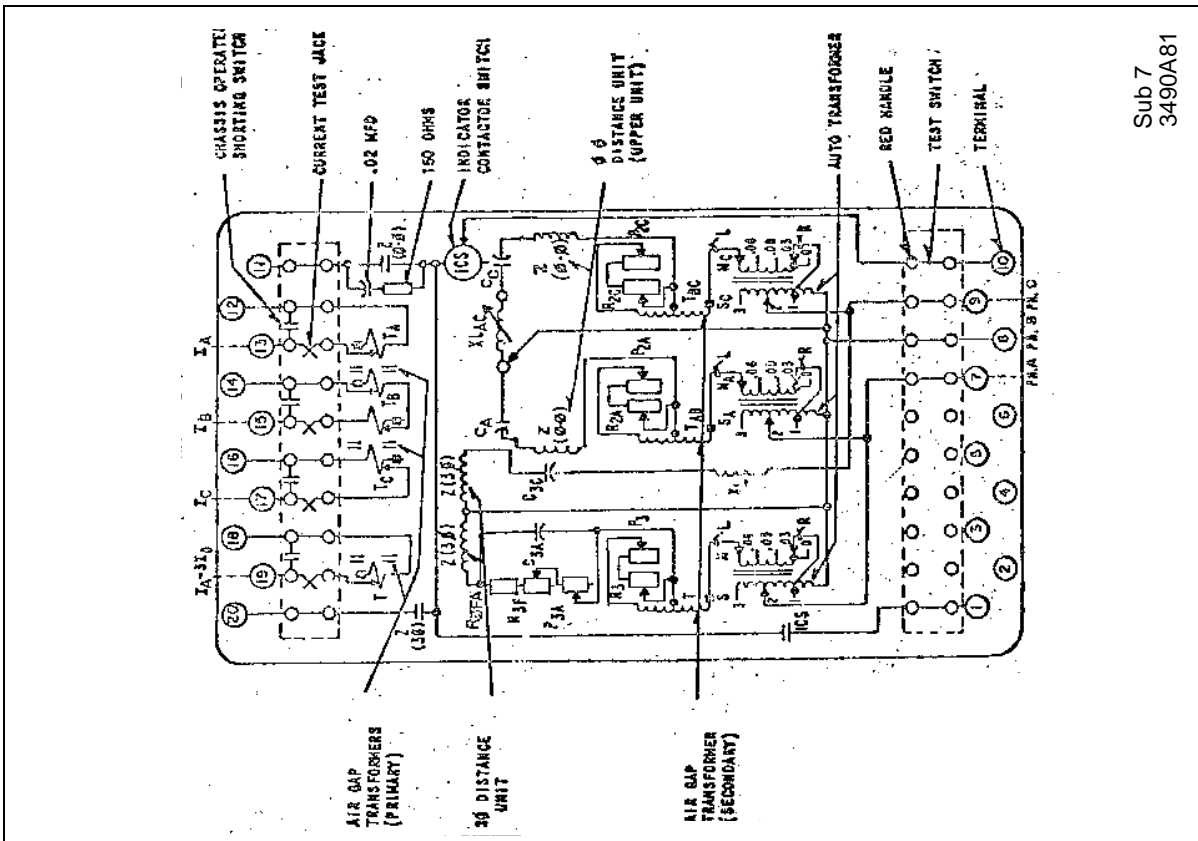

Sub 7
3490A.81

Figure 4a: Internal Schematic of KD-10 Relay (25-4.5 Ohm Range)

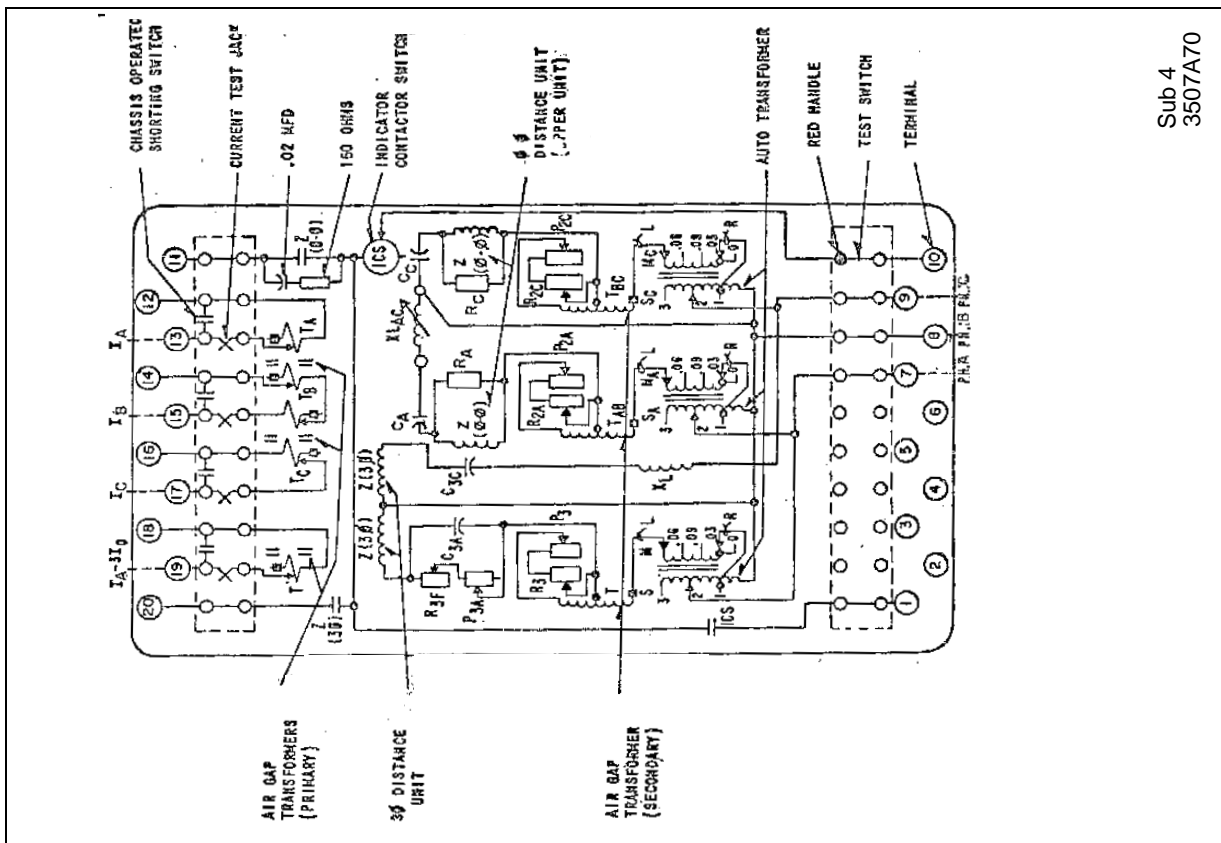

Sub 4
3507A70

Figure 5a: Internal Schematic of KD-10 Relay (.75-21.00hm Range)

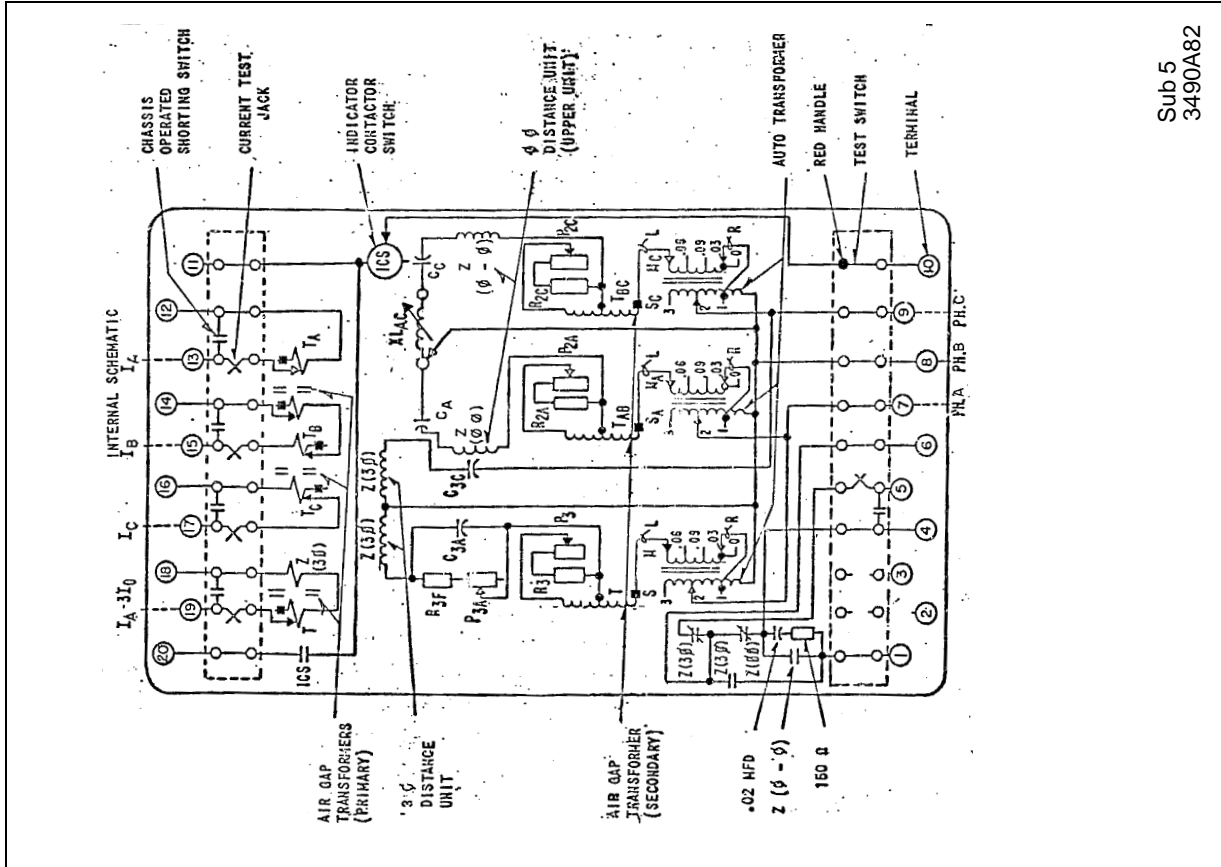

Sub 5
3490A82

Figure 5b: Internal Schematic of KD-11 Relay (.75-21.0 Ohm Range)

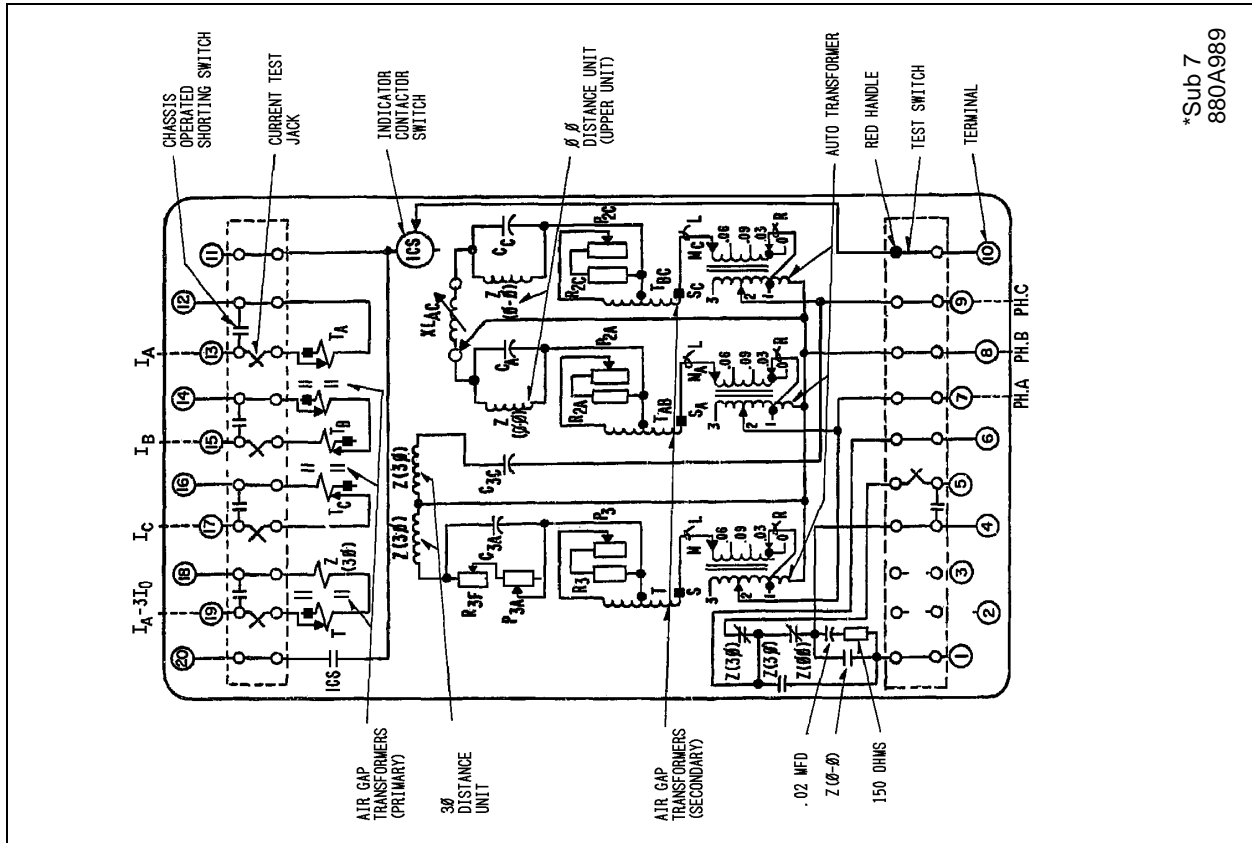

*Sub 7
880A989

Figure 7: Internal Schematic of KD-11 Relay (1.3-36.0) Ohm Range

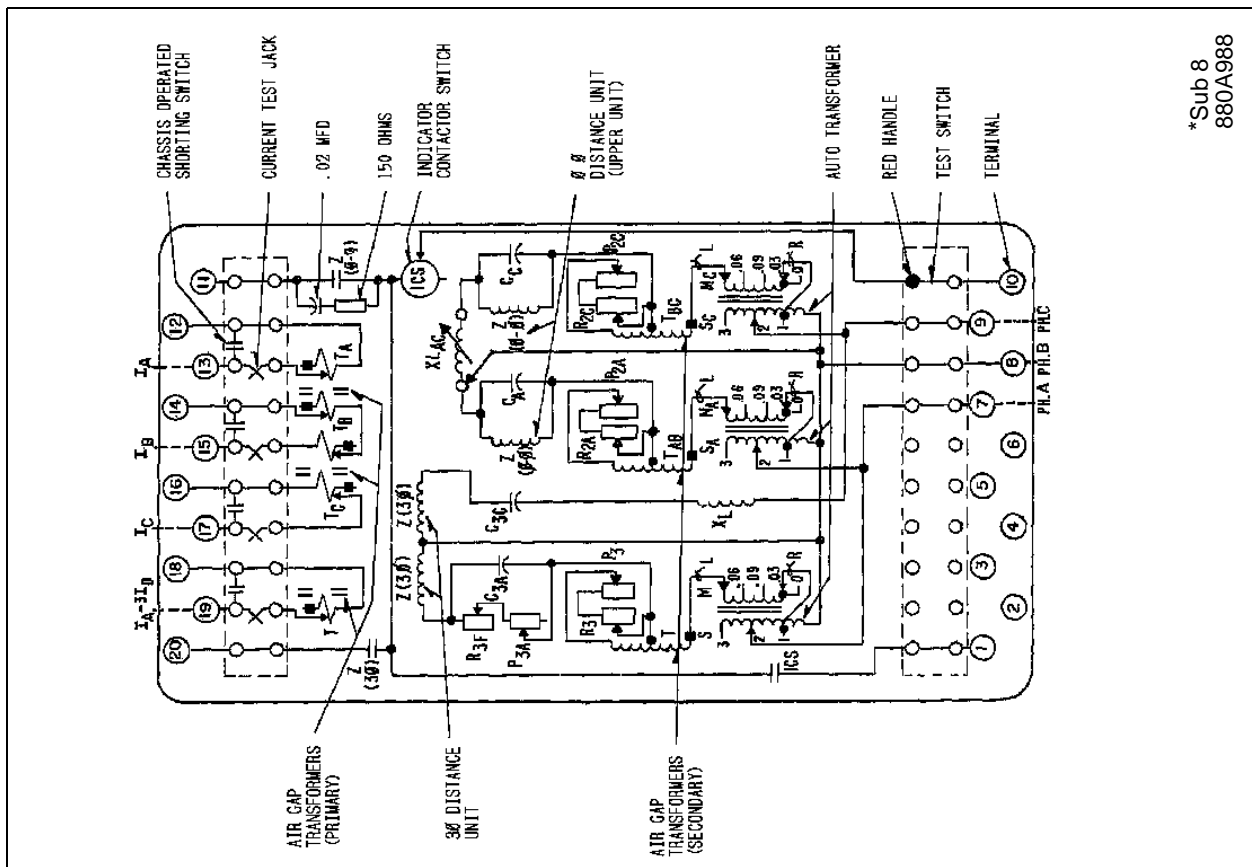

*Sub 8
880A988

Figure 6: Internal Schematic of KD-10 Relay (1.3-36.0) Ohm Range

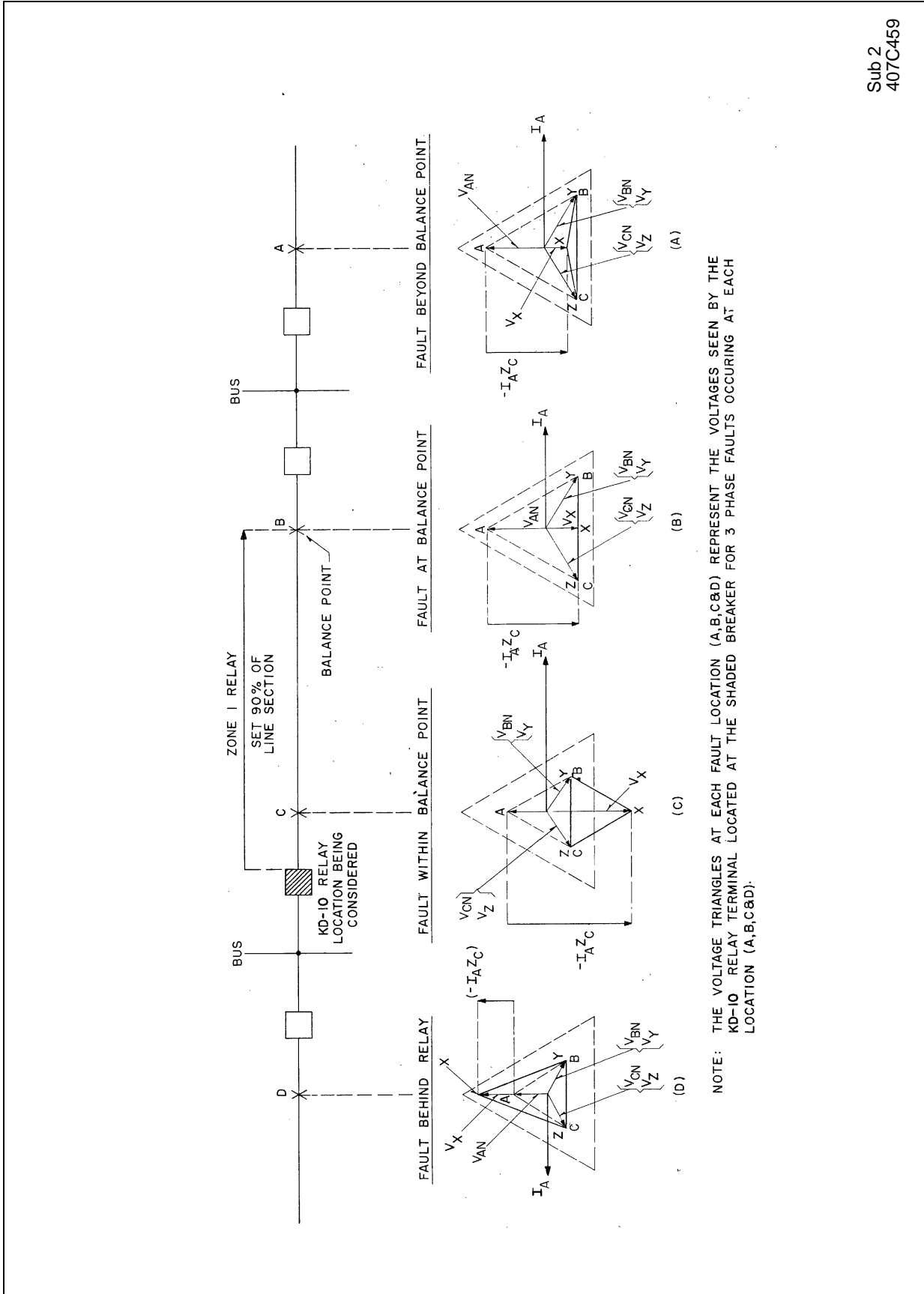

Sub 2
407C459

Figure 8: Voltage and Current Conditions for the Three-Phase Unit at the Shaded Breaker for Three-Phase Faults at Various Locations

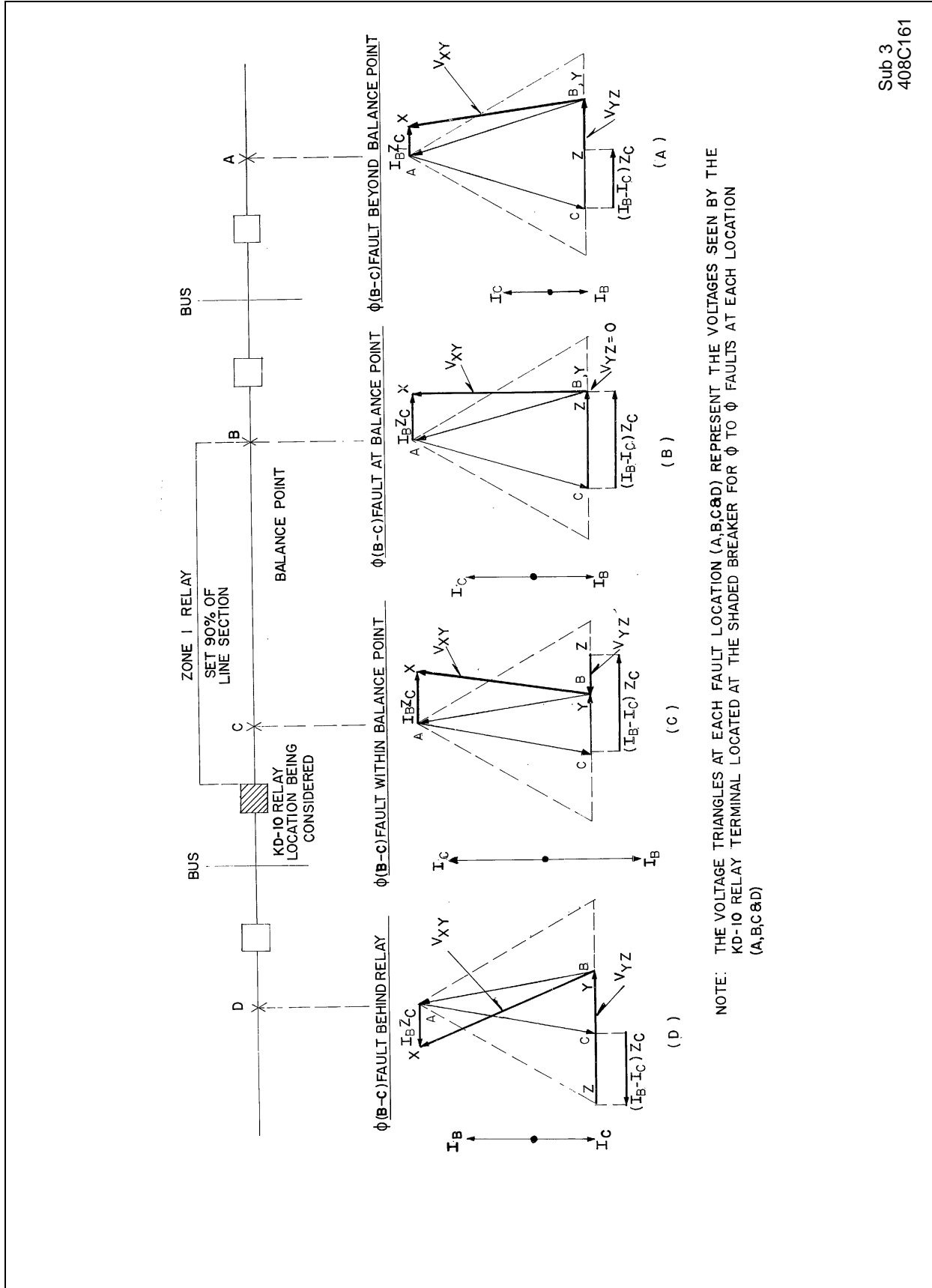

Sub 3
408C161

Figure 9: Voltage and Current Conditions for the Phase-to-Phase Unit at the Shaded Breaker for B-C faults at Various Locations

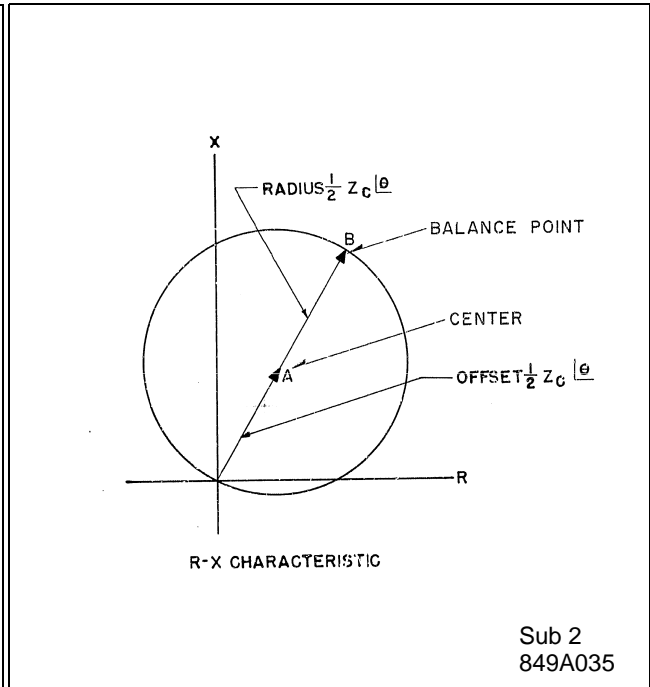
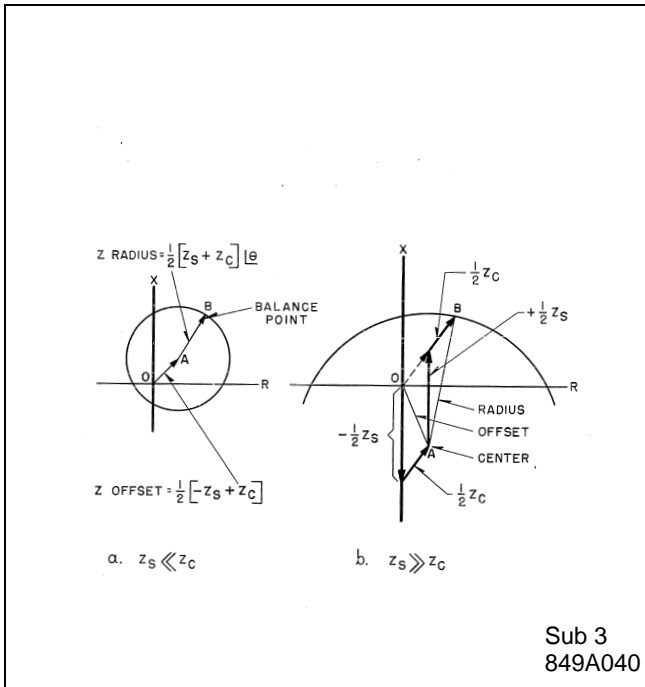

Figure 10: Impedance Circles for Phase-to-Phase Unit in the Type KD-10 and KD-11 Relay

Figure 11: Impedance Circle for Three-Phase Unit in the Type KD-10 Relay

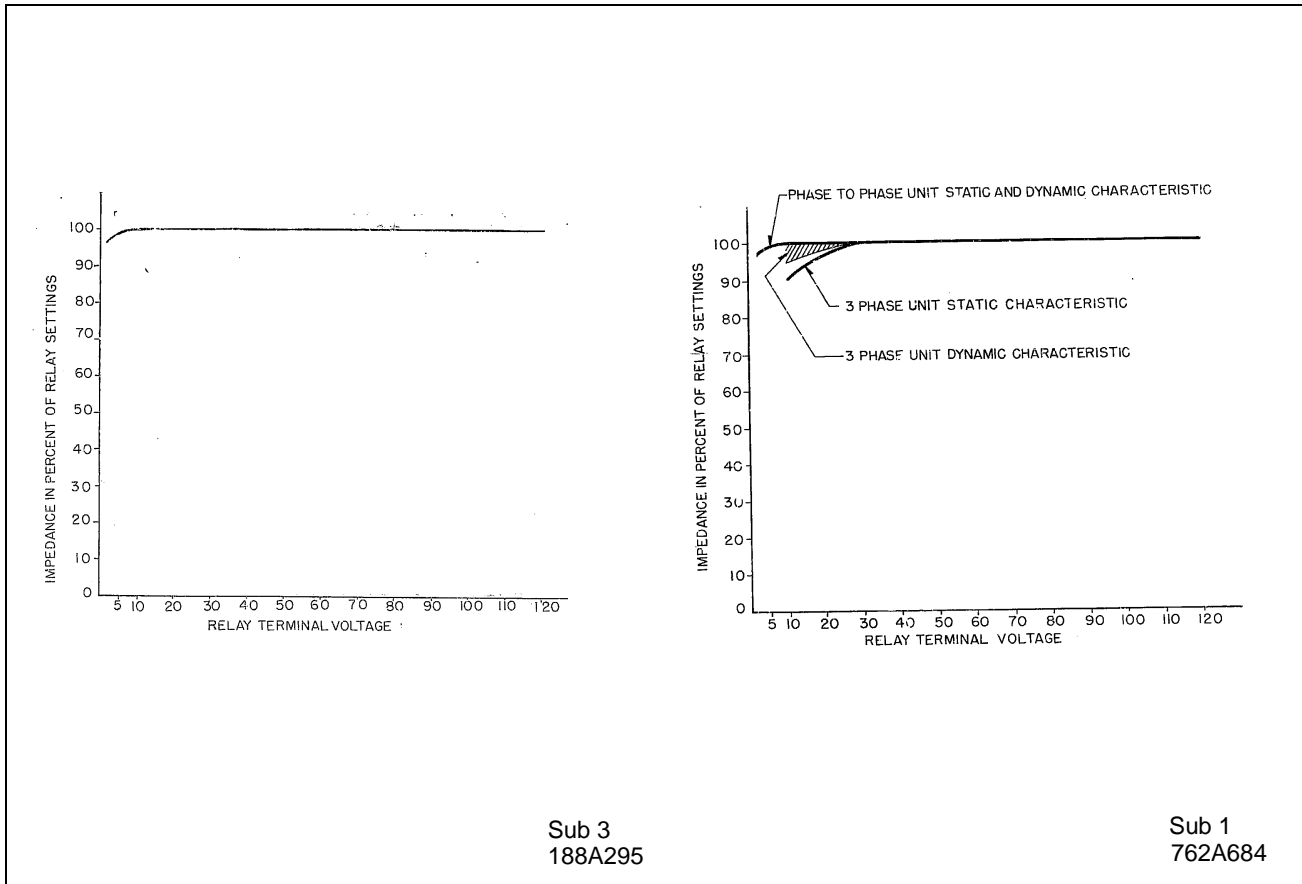

Figure 12: Impedance Curves for KD-10 Relay

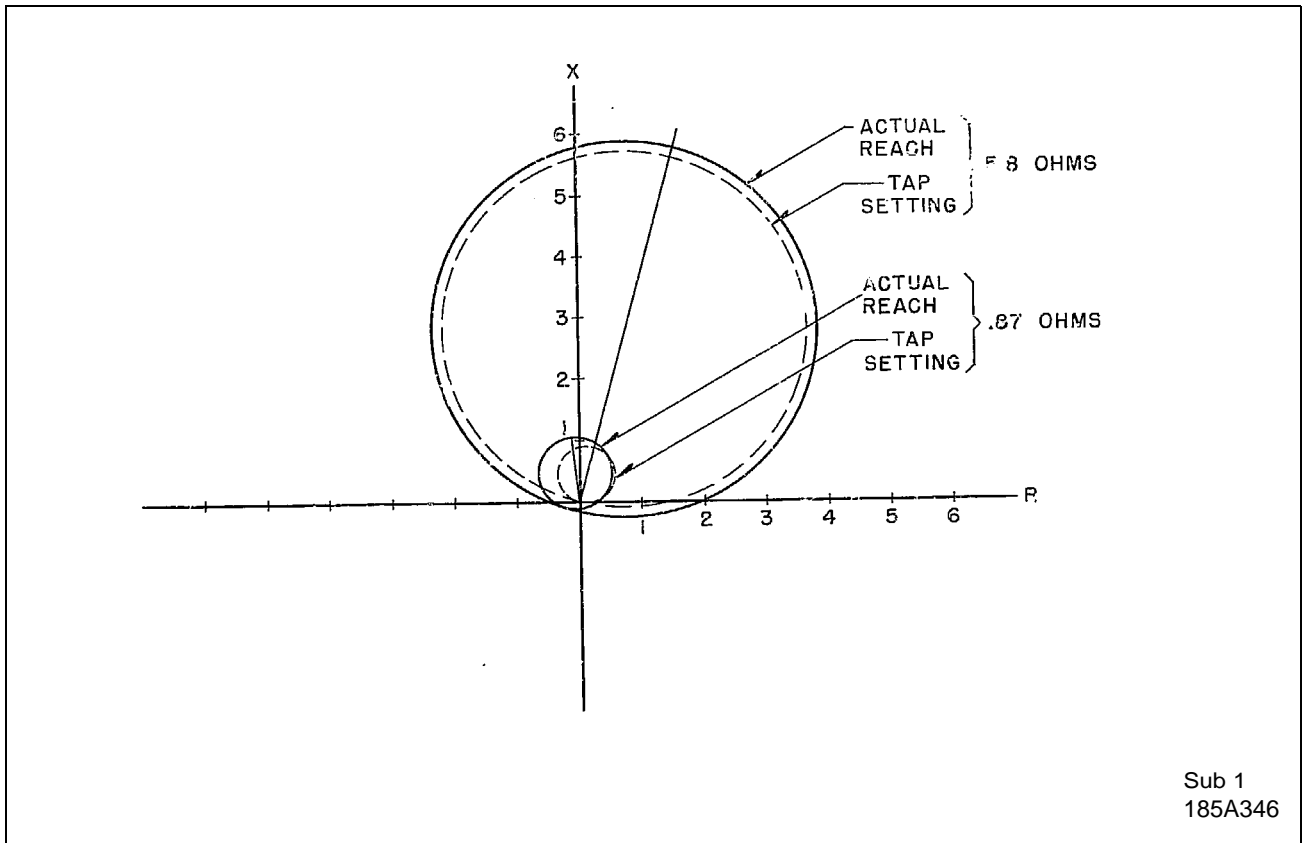

Figure 13: Impedance Circle for Three-Phase Unit in Type KD-11 Relay

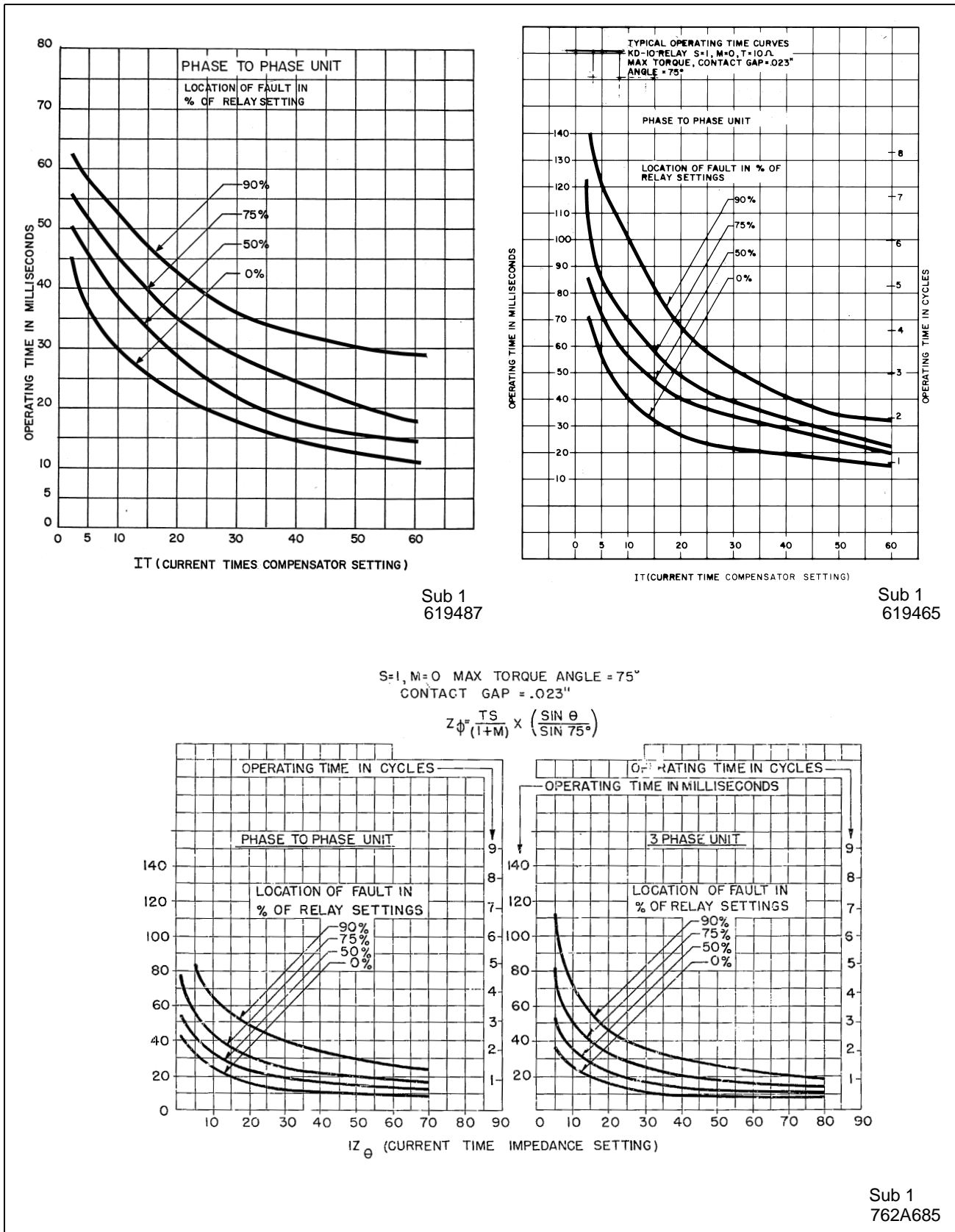

Figure 14: Typical Operating Time Curves Normal Voltages Before Fault 120 Volts, Phase-to-Phase Unit

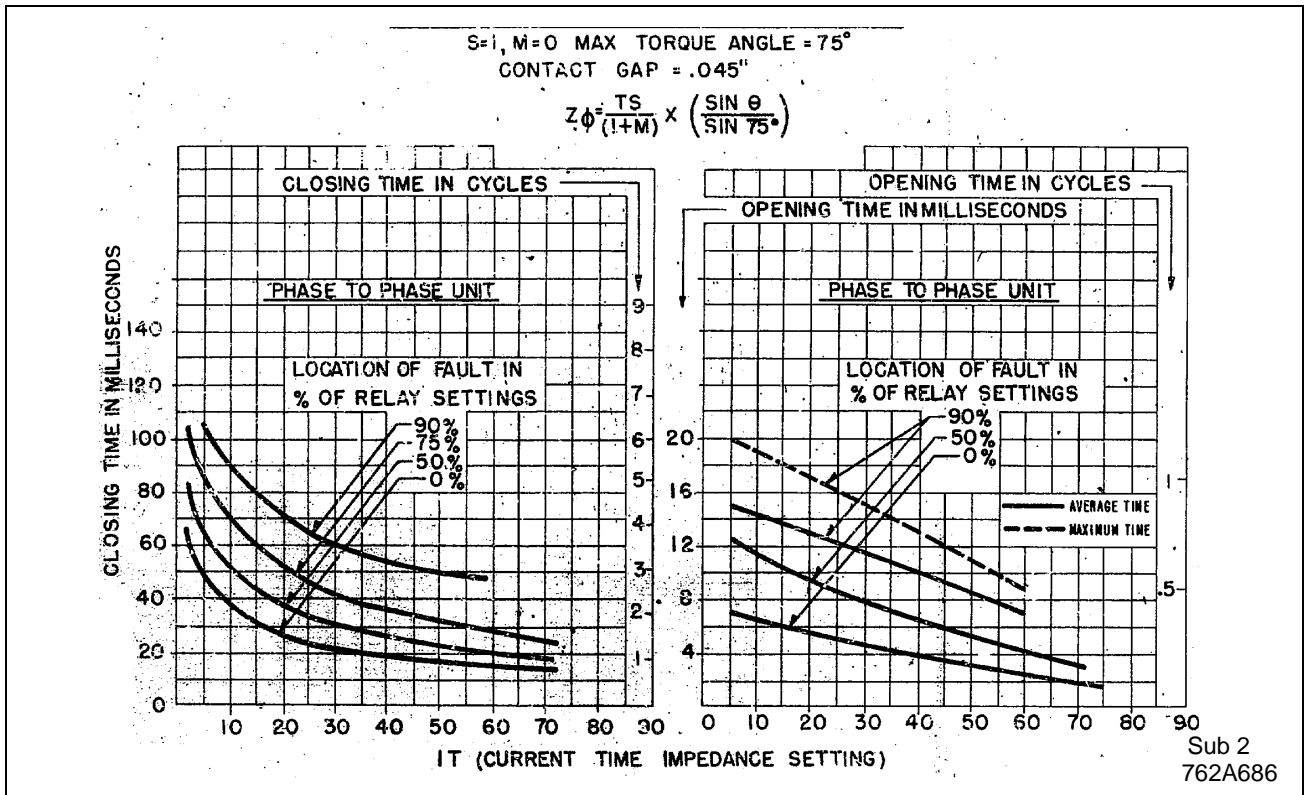

Figure 15: Typical Operating Time Curves for KD-11 Phase-to-Phase Unit

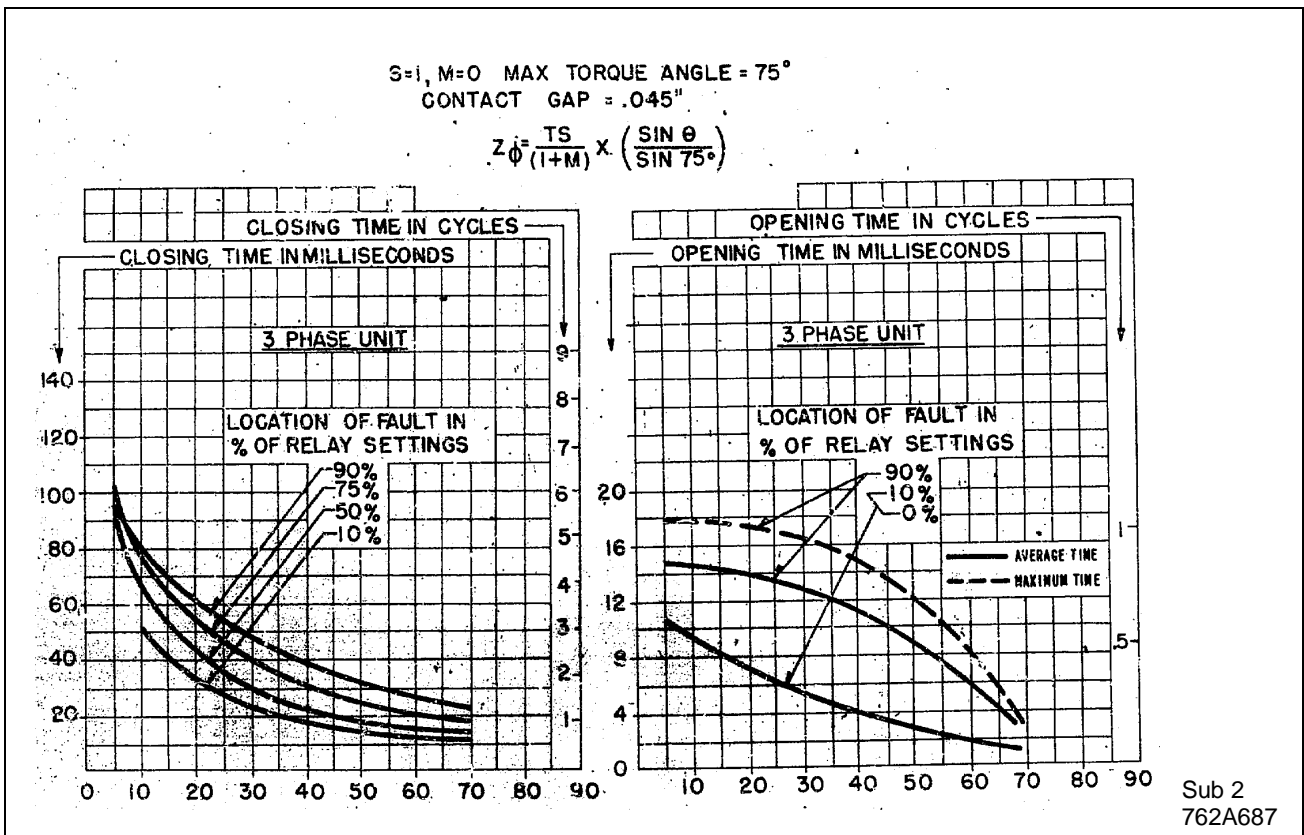
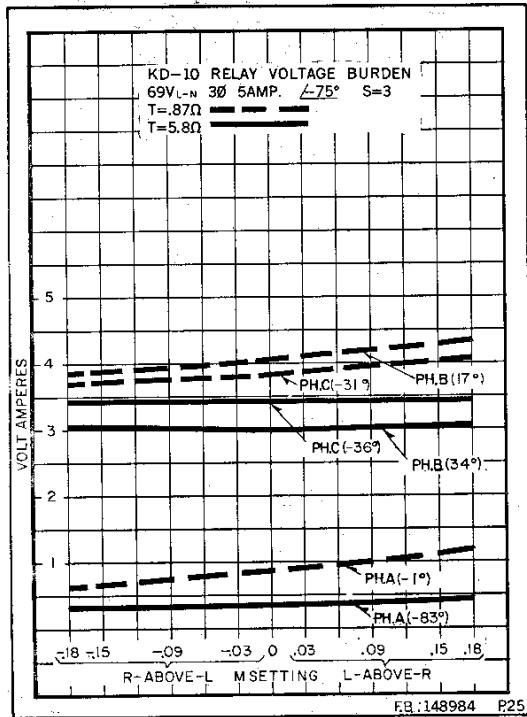
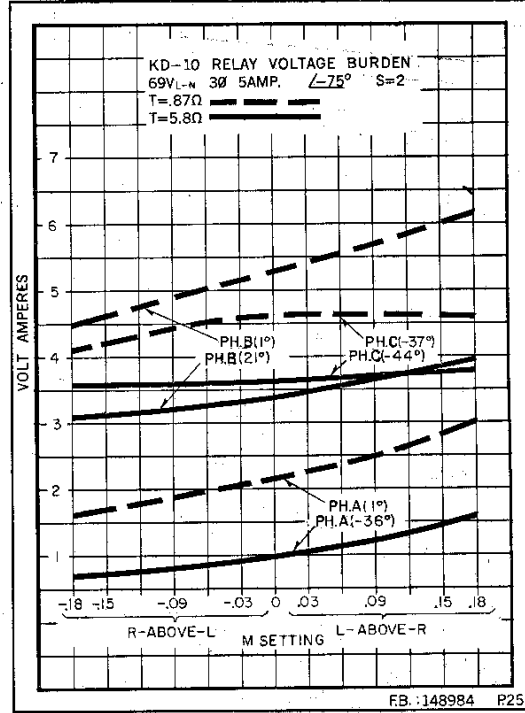
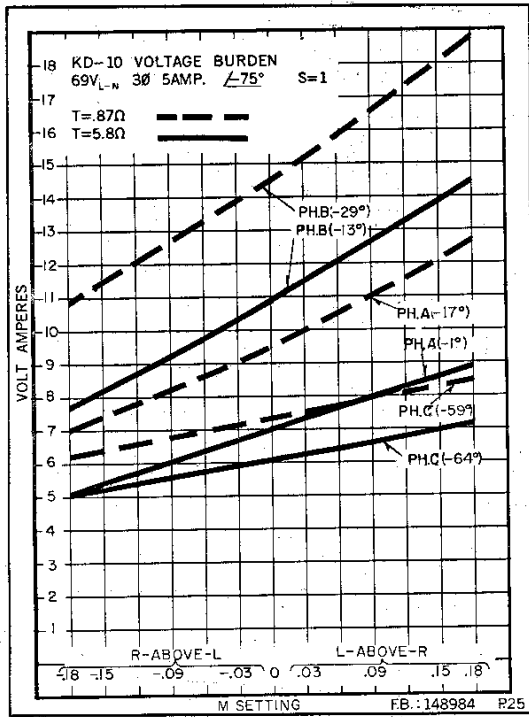

Figure 16: Typical Operating Time Curves of Type KD-11 Relay Three-Phase Unit (.75-20 Ohms)



RELAY
KD-10 CURRENT BURDEN TABLE

POTENTIAL CIRCUIT 69V_{L-N} 3Ø CURRENT=5 \angle -75°AMPS. S=1

TAP SET	T _a			T _b (BOTH)			T _c			T		
	V.A.	VAR	WATT	V.A.	VAR	WATT	V.A.	VAR	WATT	V.A.	VAR	WATT
.87	4.92	.303	.387	1.00	.515	.857	.644	.242	.597	.449	.416	.168
1.16	.594	.434	.405	1.23	.740	.983	.806	.315	.742	.618	.611	.096
1.45	.644	.552	.332	1.48	.990	1.10	.966	.423	.868	.838	.837	.044
2.03	.930	.841	.410	2.04	1.44	1.44	1.32	.640	1.155	1.37	1.36	.144
2.9	1.41	1.37	.341	3.09	2.33	2.03	1.93	1.03	1.64	2.39	2.39	0.00
4.06	2.24	2.22	.311	4.66	3.76	2.74	2.91	1.63	2.41	4.13	4.12	.289
5.8	3.76	3.75	.263	7.52	6.31	4.10	4.57	2.62	3.74	7.42	7.41	.126

FB.: 148984
P27

Figure 17a: Type KD-10 Burden Curves

Sub 2
1426C53

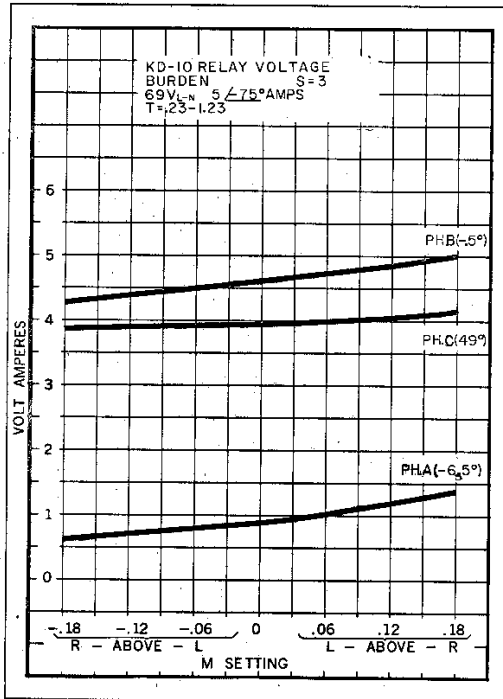
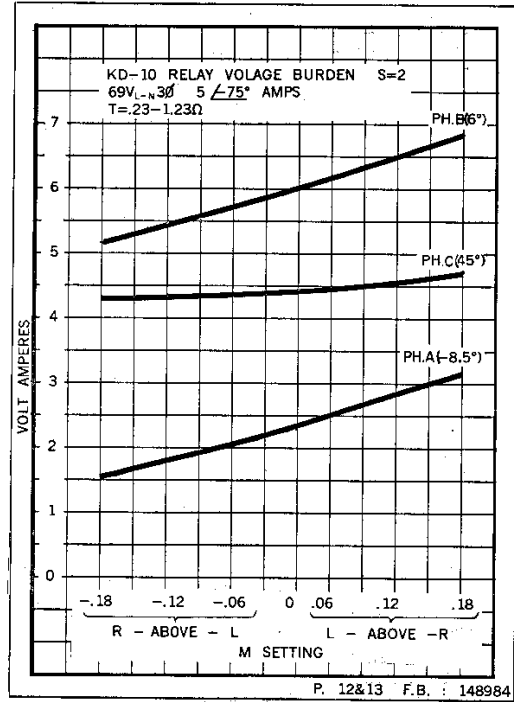
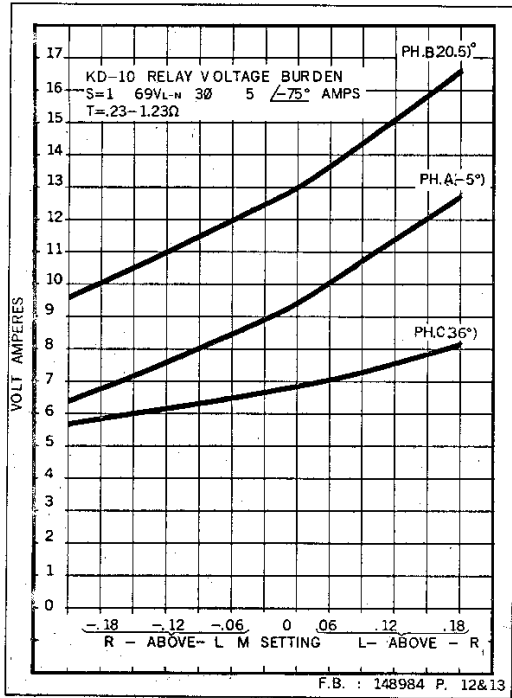

RELAY
KD-10 CURRENT BURDEN TABLE

POTENTIAL CIRCUIT 69V_{L-N} 30 CURRENT=50 $\angle 75^\circ$ AMPS. M=0 S=1

TAP SET	T _a			T _b (BOTH)			T _c			T		
	V.A.	VAR.S	WATT	V.A.	VAR.S	WATT	V.A.	VAR.S	WATT	V.A.	VAR.S	WATT
.23	.433	.038	.431	.560	.135	.543	.441	.084	.433	.495	.169	.465
.307	.489	.093	.480	.886	.229	.856	.470	.137	.450	.499	.234	.440
.383	.456	.163	.426	.804	.352	.723	.540	.193	.504	.550	.323	.445
.537	.478	.314	.361	1.580	.692	1.420	.706	.364	.605	.654	.462	.462
.690	.615	.538	.298	1.469	1.039	1.039	.974	.559	.798	.809	.654	.476
.920	1.166	.943	.685	2.140	1.834	1.102	1.438	.943	1.086	1.098	.969	.514
1.23	1.658	1.656	.058	3.477	3.126	1.523	2.212	1.509	1.616	1.590	1.440	.673

F.B. : 148984
P2

Sub 2
1426C54

Figure 17:b Type KD-10 Burden Curves

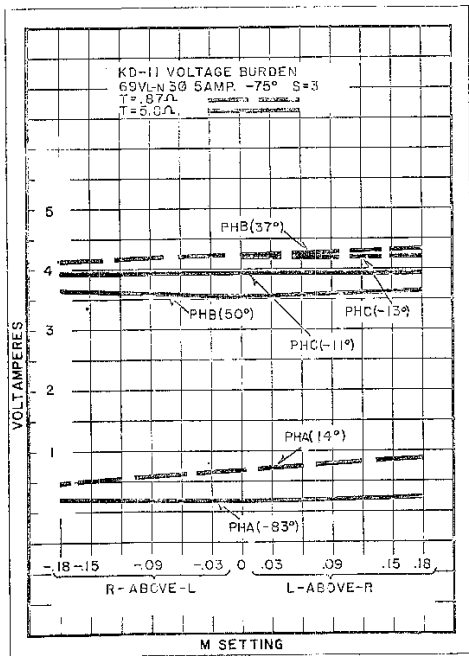
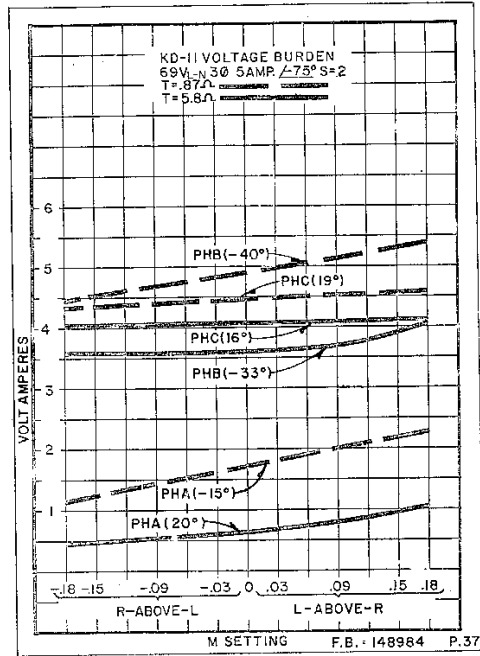
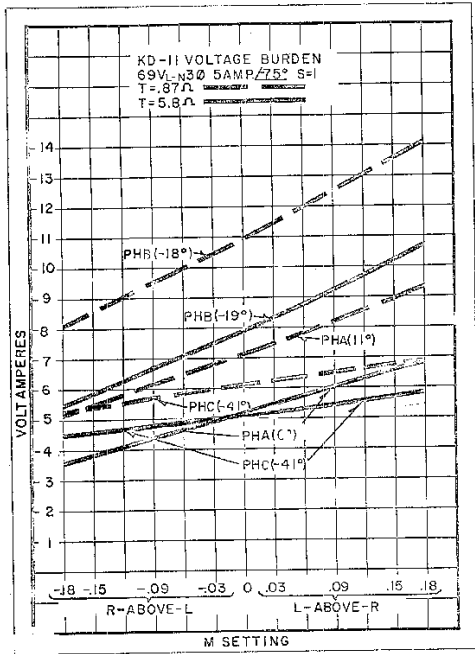

RELAY
 KD-11 CURRENT BURDEN TABLE
 POTENTIAL CIRCUIT 69V_{L-N} 3Ø CURRENT=5.0/75° AMPS. S=1

TAP SET	T _a			T _c BOTH			T _c			T		
	V.A.	VAR.S	WATT	V.A.	VAR.S	WATT	V.A.	VAR.S	WATT	V.A.	VAR.S	WATT
.87	.359	.232	.287	1.28	.415	1.21	.562	.164	.537	.649	.373	.532
1.16	.487	.338	.350	1.45	.591	1.33	.705	.230	.667	.725	.531	.495
1.45	.560	.453	.330	1.66	.752	1.47	.853	.306	.796	.854	.700	.490
2.03	.792	.700	.372	2.14	1.16	1.79	1.15	.485	1.04	1.25	1.15	.487
2.90	1.24	1.18	.384	3.02	1.94	2.31	2.40	.821	2.26	2.08	2.00	.574
4.06	2.01	1.96	.418	4.46	3.21	3.09	2.59	1.33	2.22	3.68	3.58	.891
5.80	3.45	3.43	3.61	7.09	5.74	4.17	4.15	2.26	3.48	6.85	6.65	1.66

F.B. : 148984
 P2

Figure 18a: Type KD-11 Burden Curves

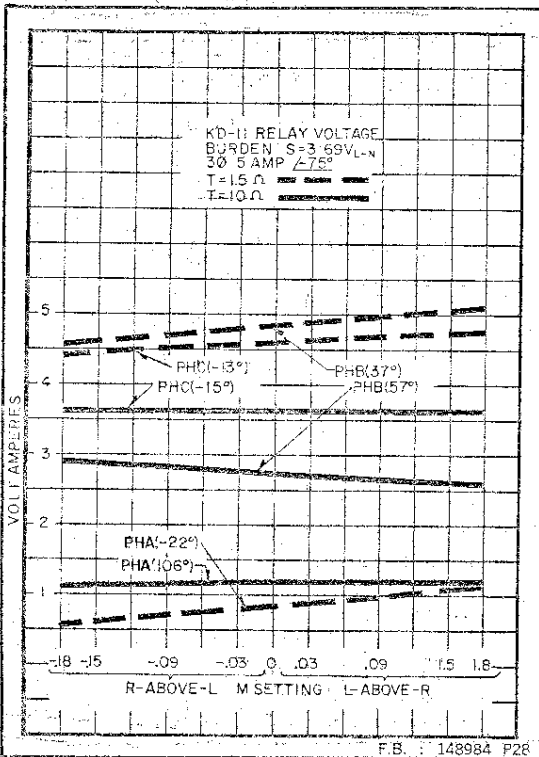
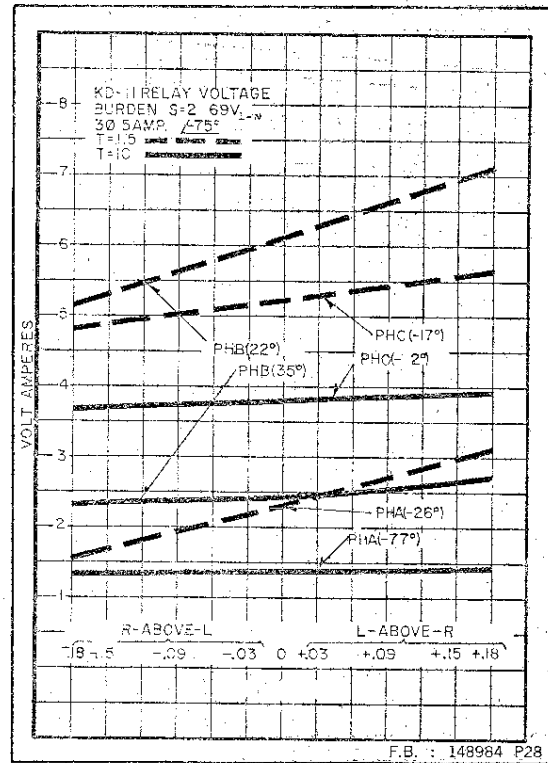
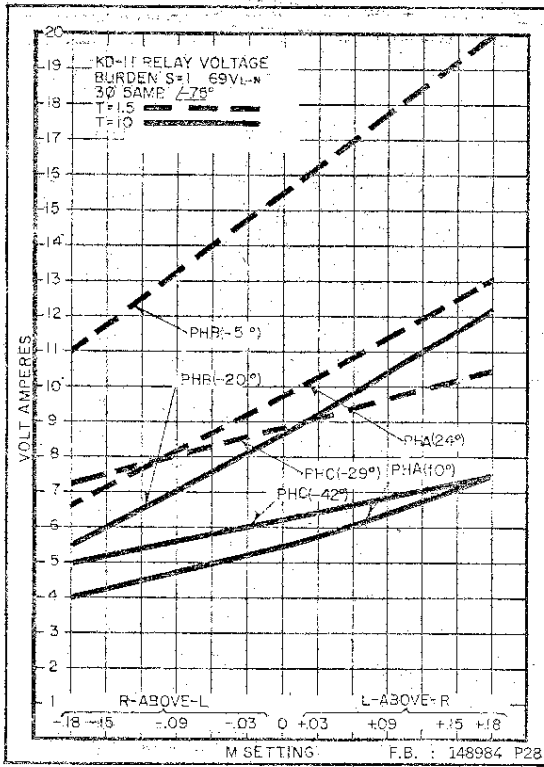

RELAY
KD-11 CURRENT BURDEN TABLE

POTENTIAL CIRCUIT 69V_{L-N} 30 CURRENT= $5\alpha \angle 75^\circ$ AMPS. S=1

TAP SET	T _a			T _b (BOTH)			T _c			T		
	V.A.	VARS	WATT	V.A.	VARS	WATT	V.A.	VARS	WATT	V.A.	VARS	WATT
1.5	.416	.411	.065	1.05	.968	.409	.771	.573	.516	.664	.616	.249
2.0	.577	.576	.020	1.40	1.31	.478	.998	.765	.642	.942	.906	.260
2.5	.768	.748	.173	1.75	1.67	.510	1.22	.964	.753	1.28	1.26	.245
3.51	1.16	1.12	.282	2.51	2.40	.733	1.68	1.32	1.03	2.20	2.17	.383
5.0	1.82	1.79	.348	3.79	3.56	1.30	2.45	1.82	1.64	4.07	4.01	.708
7.02	2.82	2.80	.344	5.68	5.19	2.31	3.56	2.48	2.56	7.39	7.17	1.79
10	4.66	4.66	0.00	9.11	7.98	4.42	5.54	3.33	4.43	14.27	13.64	4.17

F.B. : 148984 P29

Sub 2
1426C52

Figure 18b: Type KD-11 Burden Curves

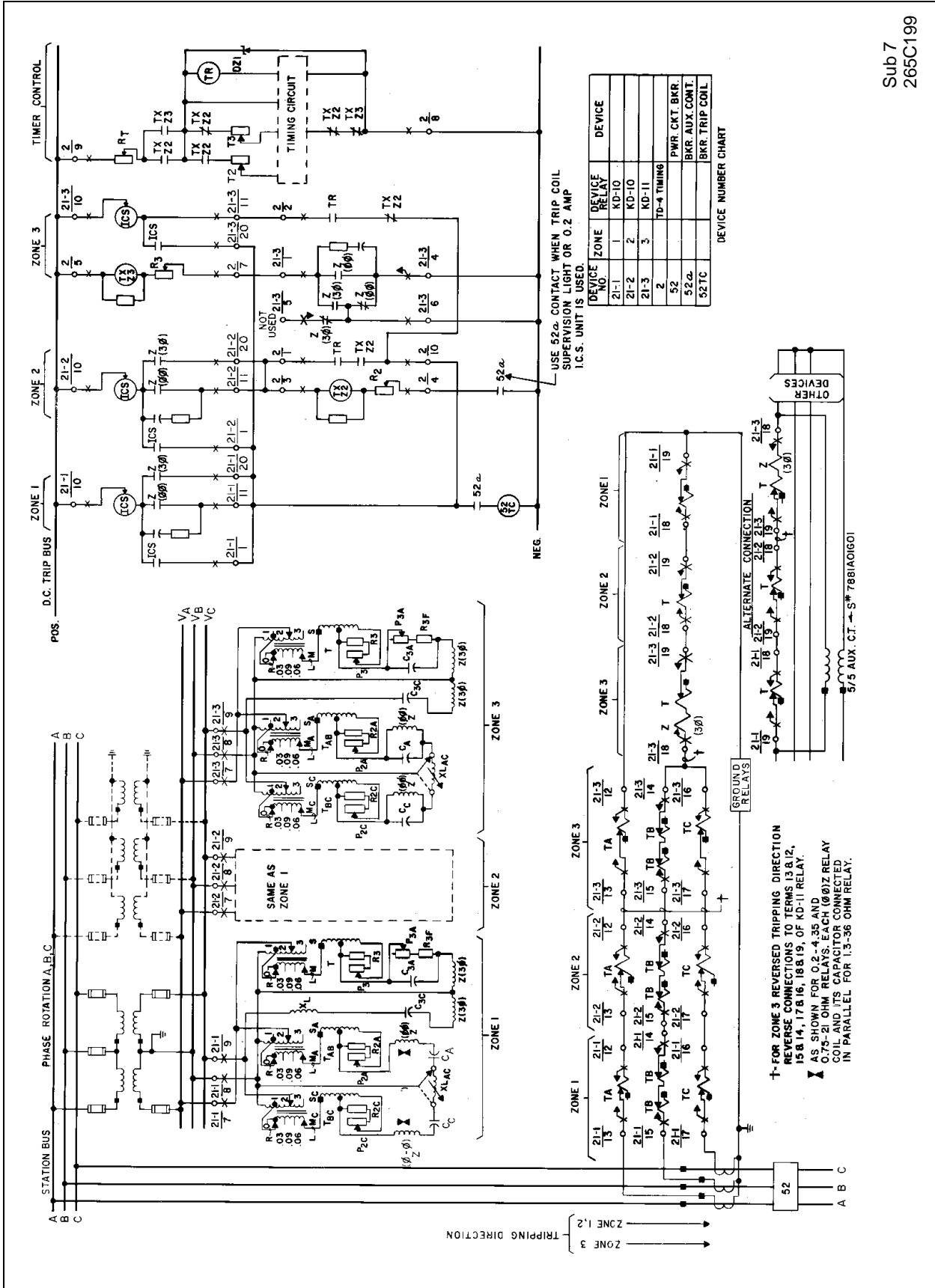

Sub 7
265C199

Figure 19: External Schematic: Two KD-10 Relays, One KD-11, and a Type KD-4 Timing Relay

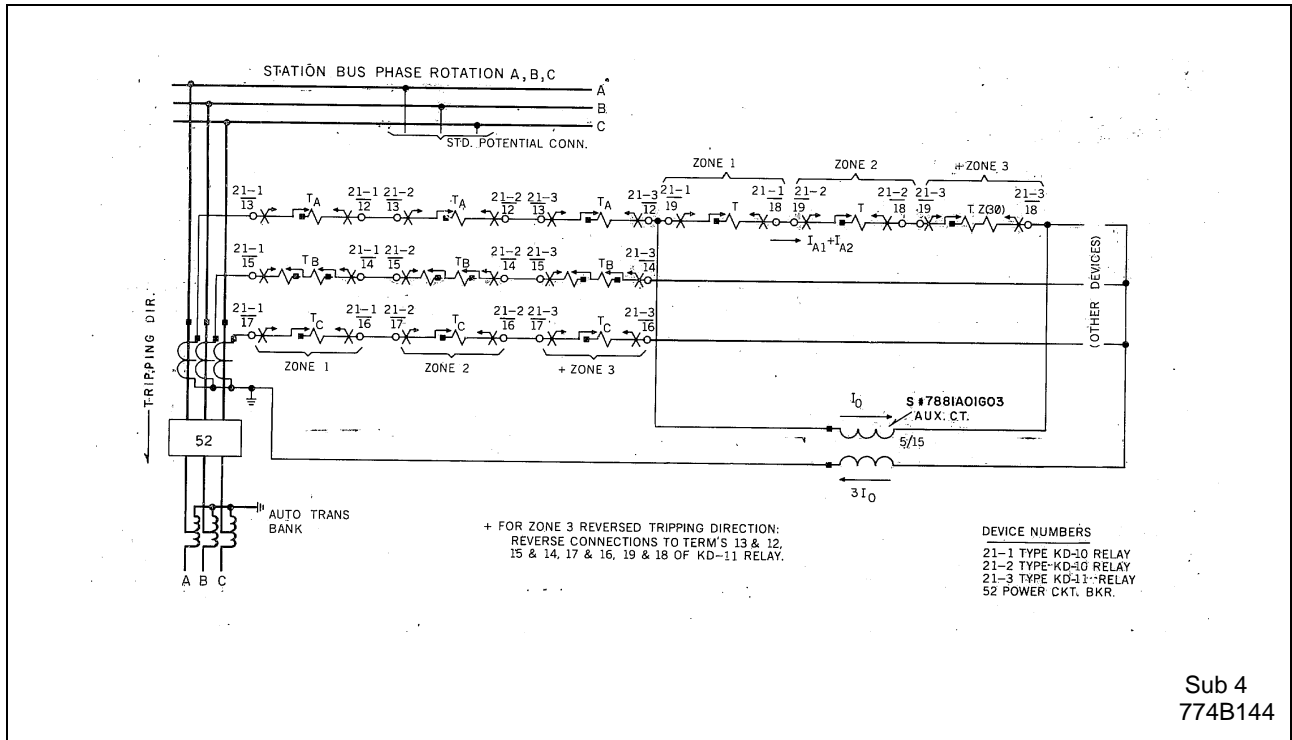

Figure 20: External Schematic: Two KD-10 Relays, One KD-11 Relay, Autotransformer Termination

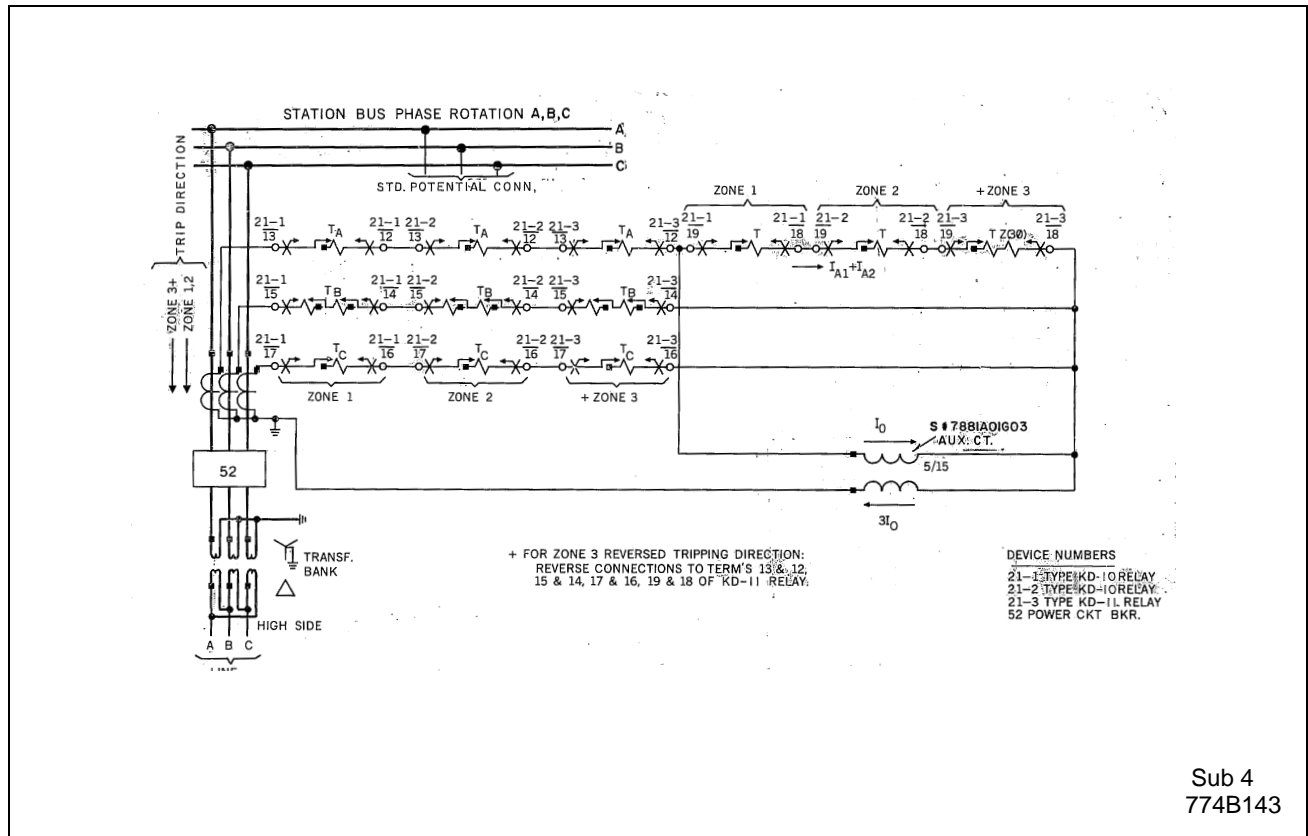

Figure 21: External Schematic: Two KD-10 Relays, One KD-11 Relay, Wye-Delta Bank Termination with Grounded Wye on Relay Side

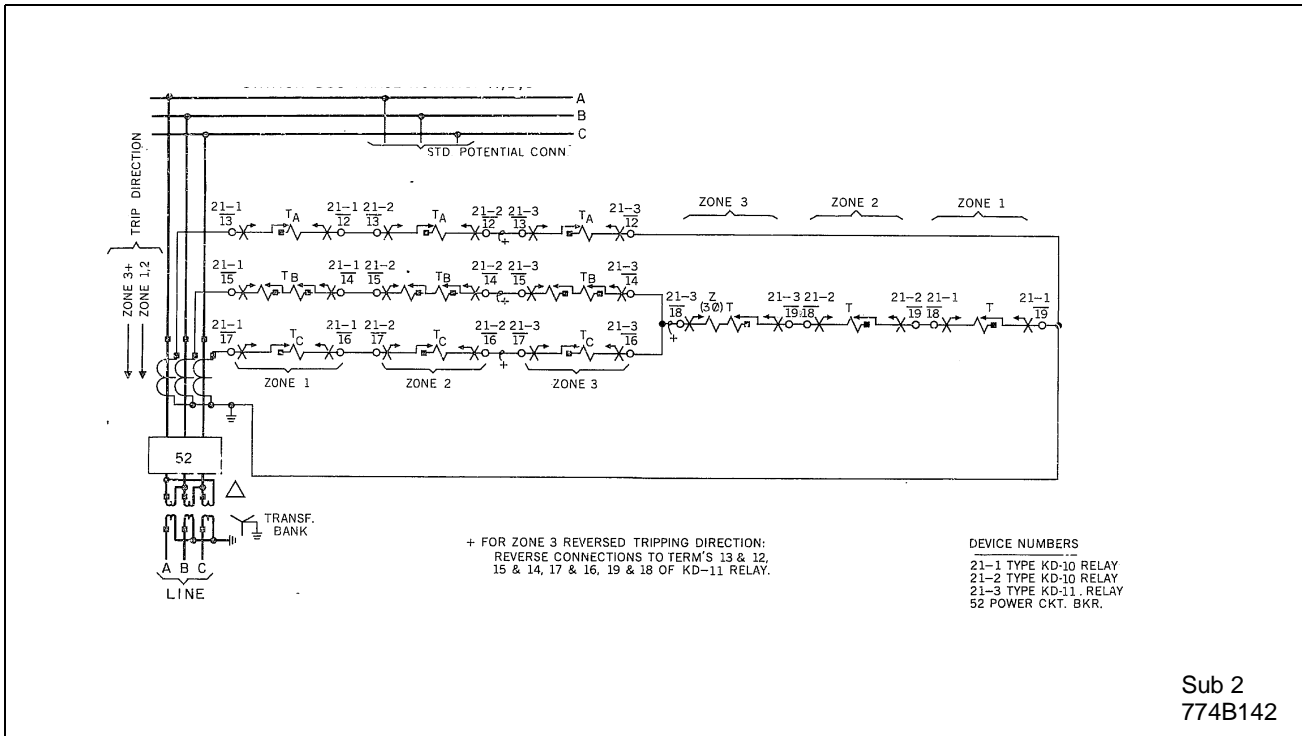

Figure 22: External Schematic: Two Type KD-10 Relays, One KD-11 Relay, Wye-Delta Bank Termination with Delta on Relay Side

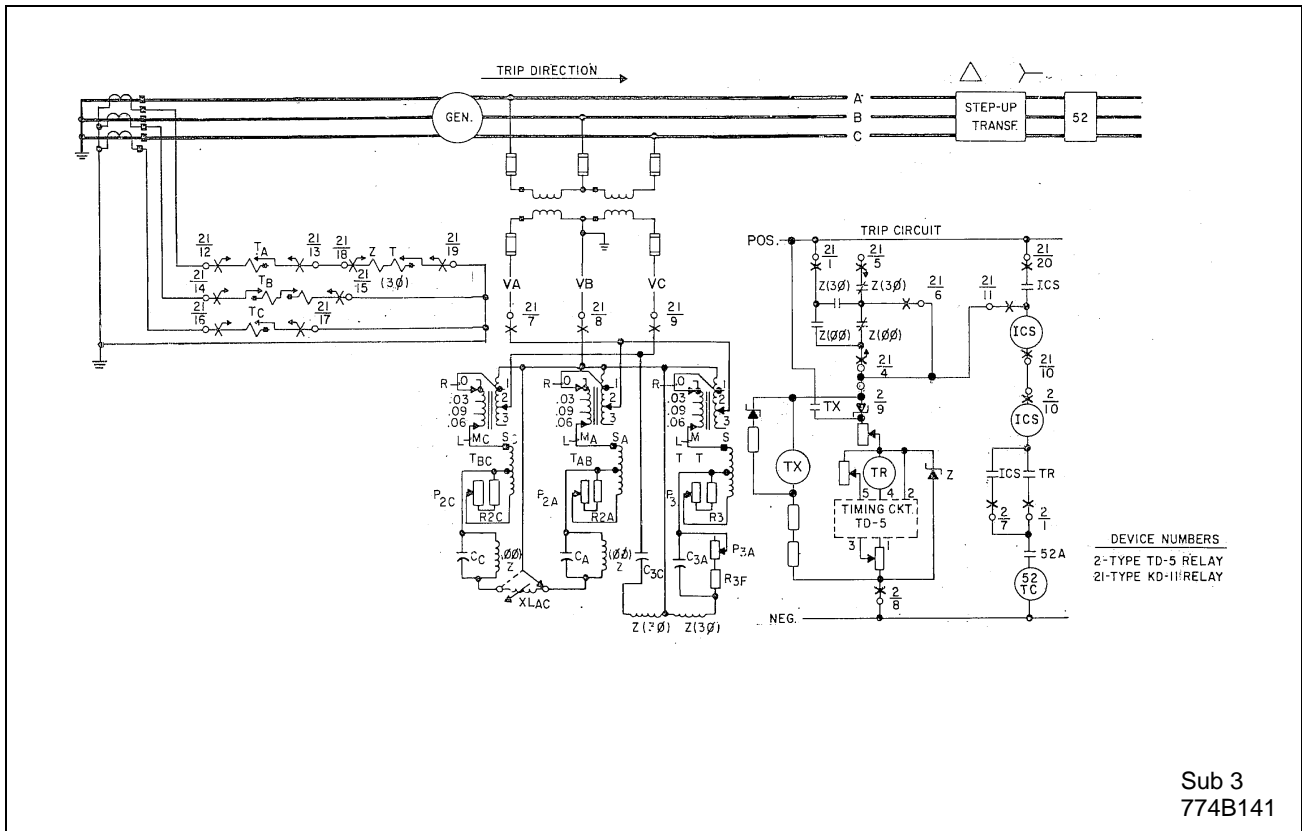
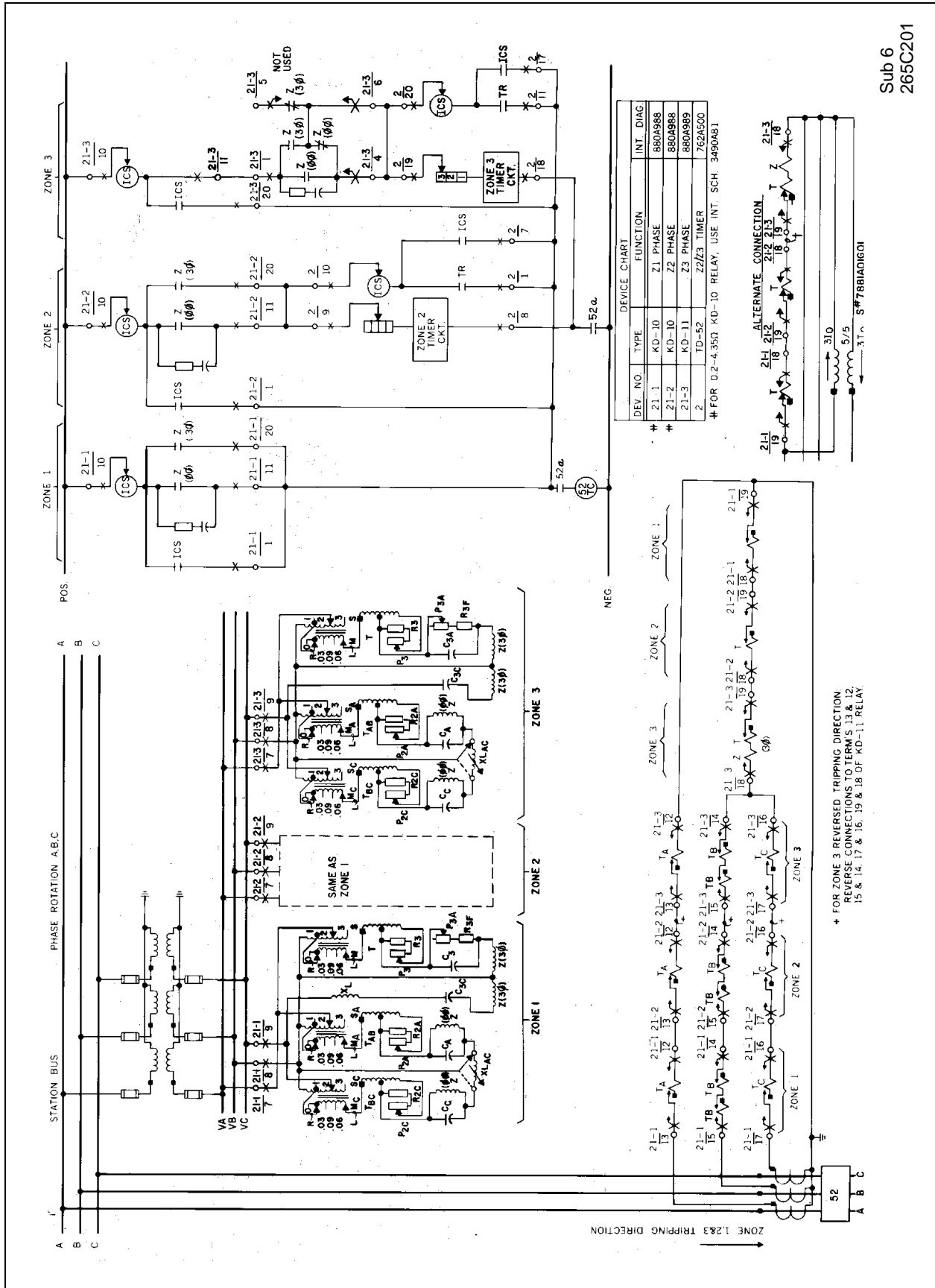

Figure 23: External Schematic: Type KD-11 Relay with Type TD-5 Timing Relay for Generator Back Up Protection



Sub 6
265C201

Figure 24: External Schematic: Two Type KD-10 Relays, One Type KD-11 with TD-52 Timing Relay

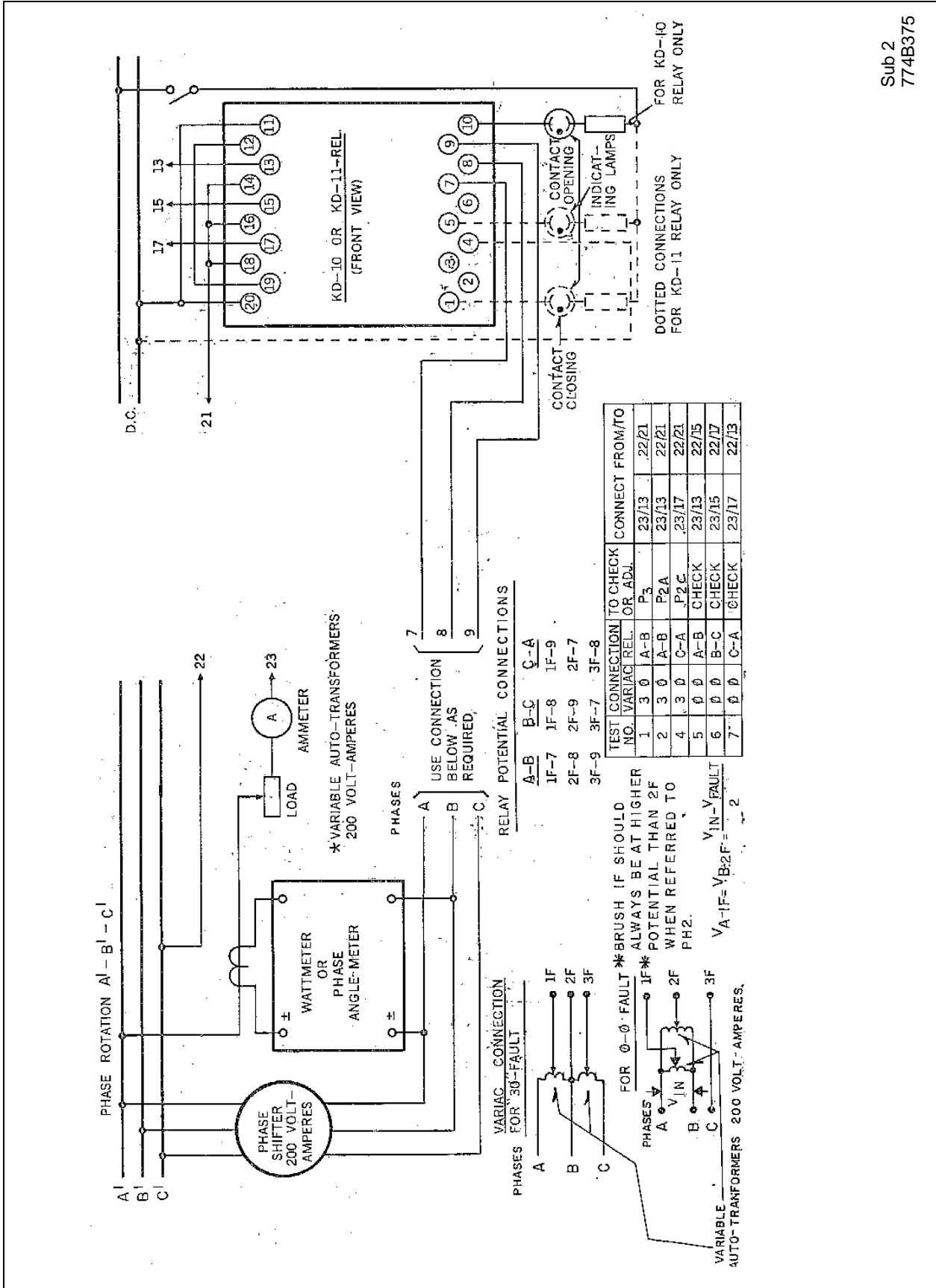
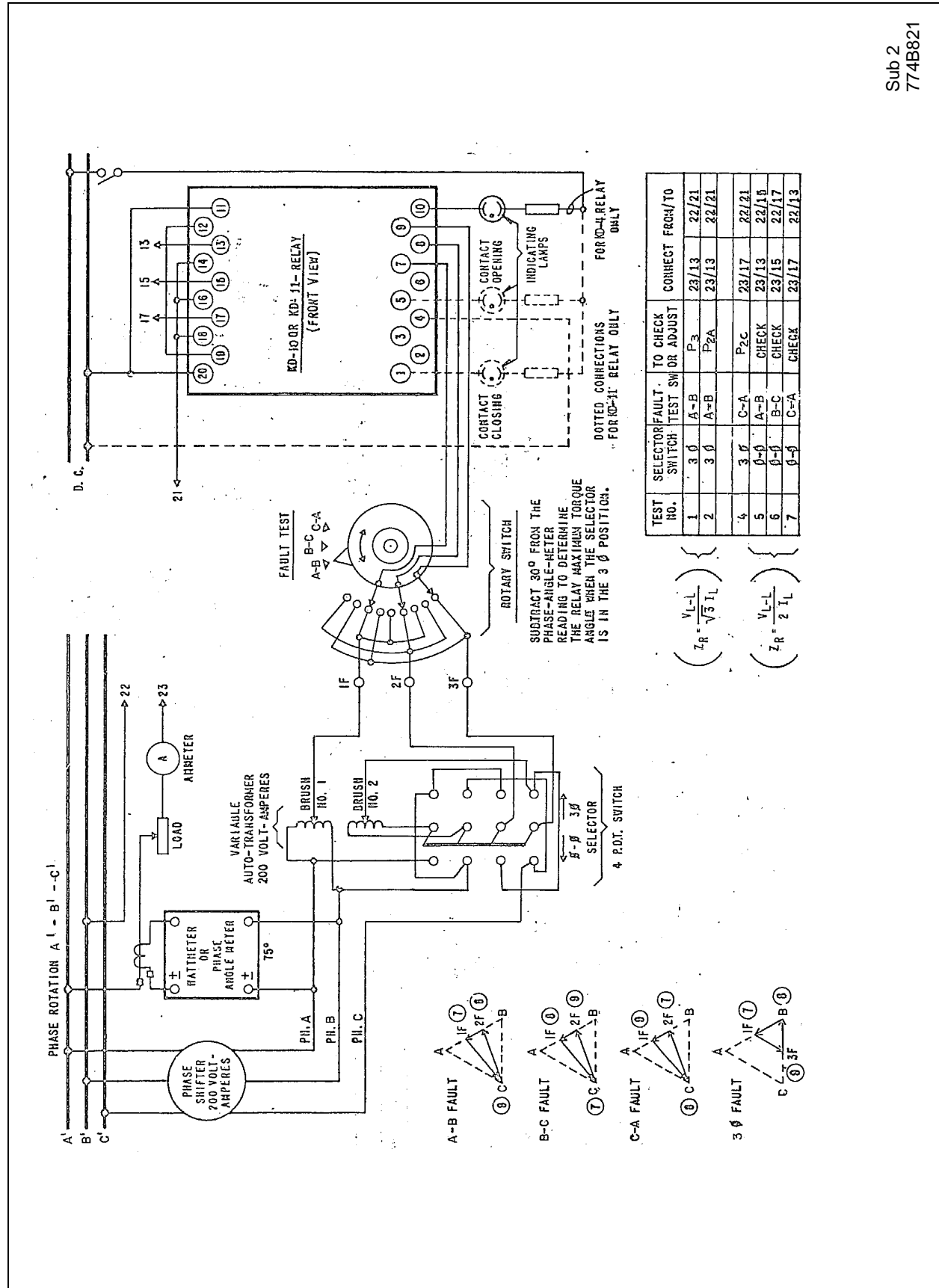

Figure 25: Basic Test Connections for Type KD-10 and KD-11 Relays



Sub 2
774B821

Figure 26: Test Connections for Type KD-10 and KD-11 Relays Using Auxiliary Switches

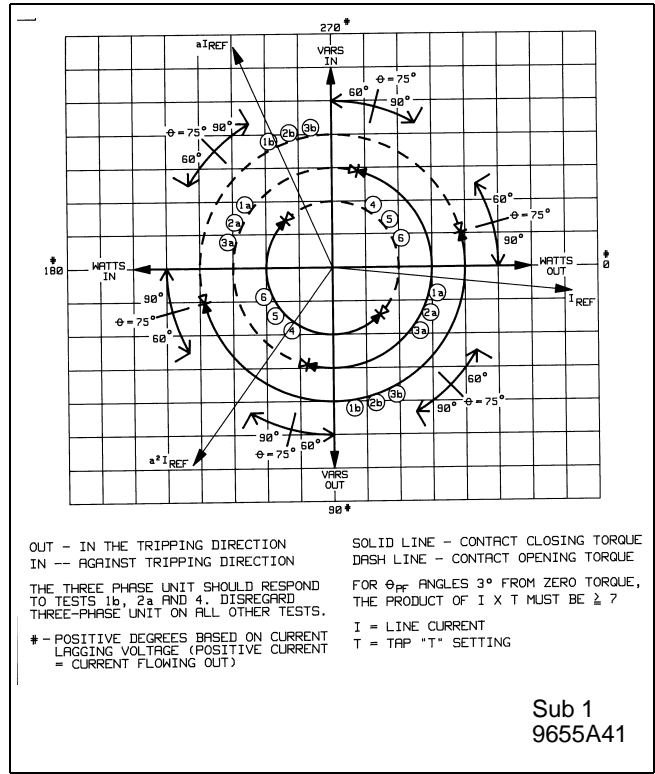
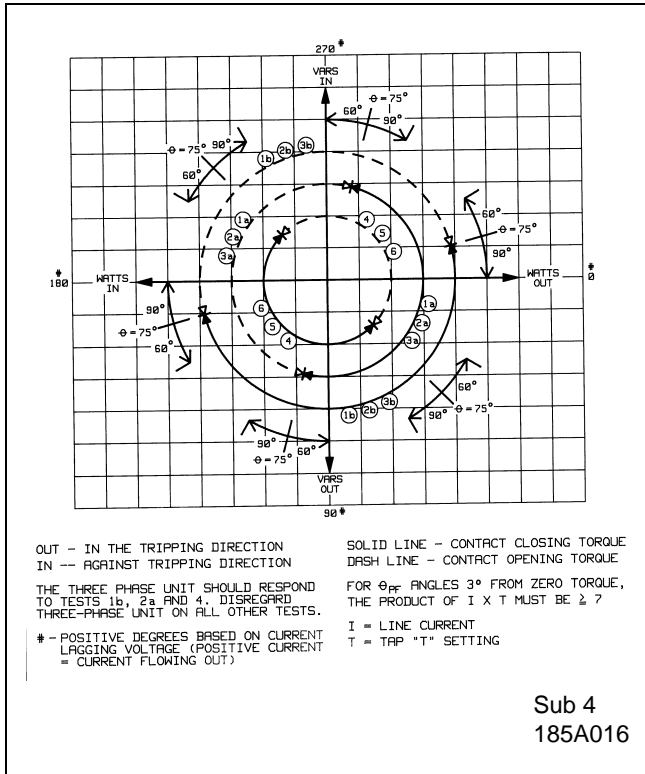

Figure 27: Phase Diagram for Current Circuit Verification and Identification

Figure 28: Phase Diagram Showing Assumed Load Conditions

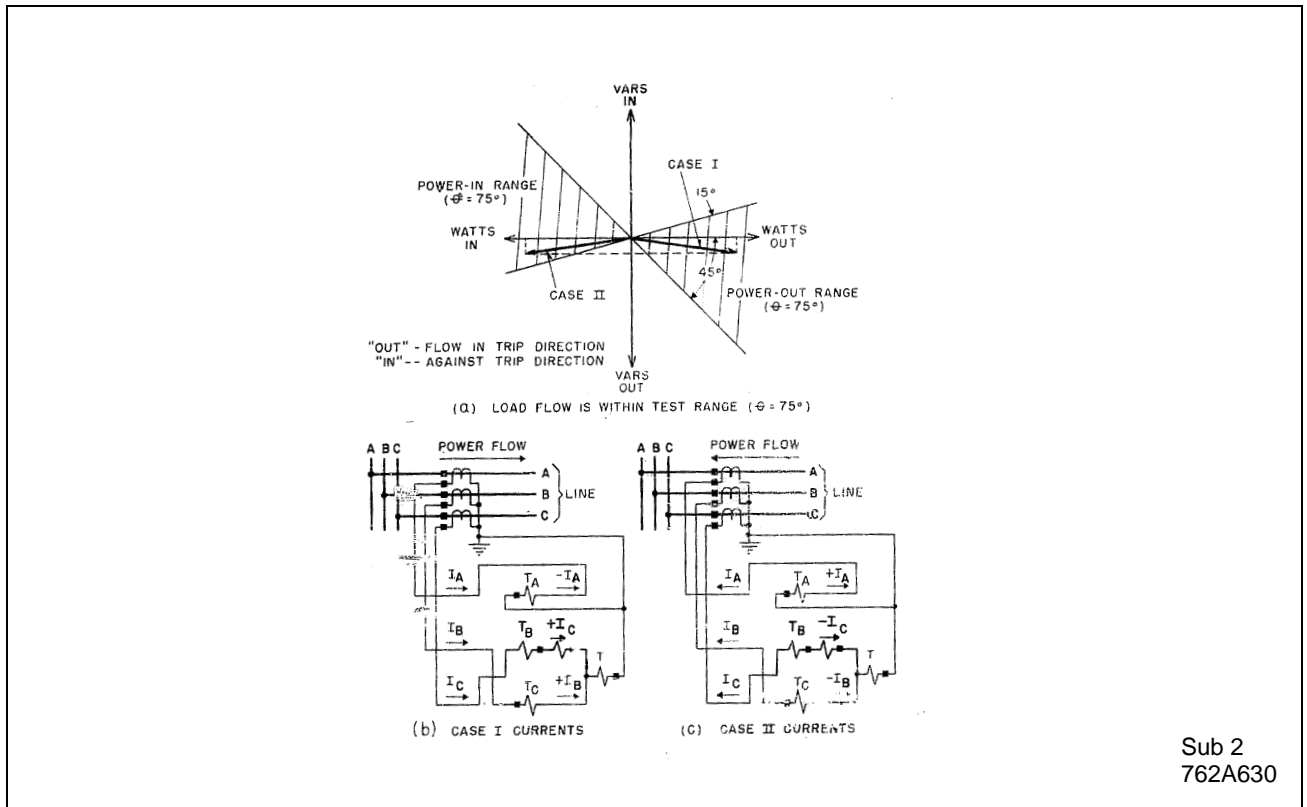

Figure 29: Actual Wiring for the Assumed Test Results

RESERVED FOR NOTES

RESERVED FOR NOTES

RESERVED FOR NOTES

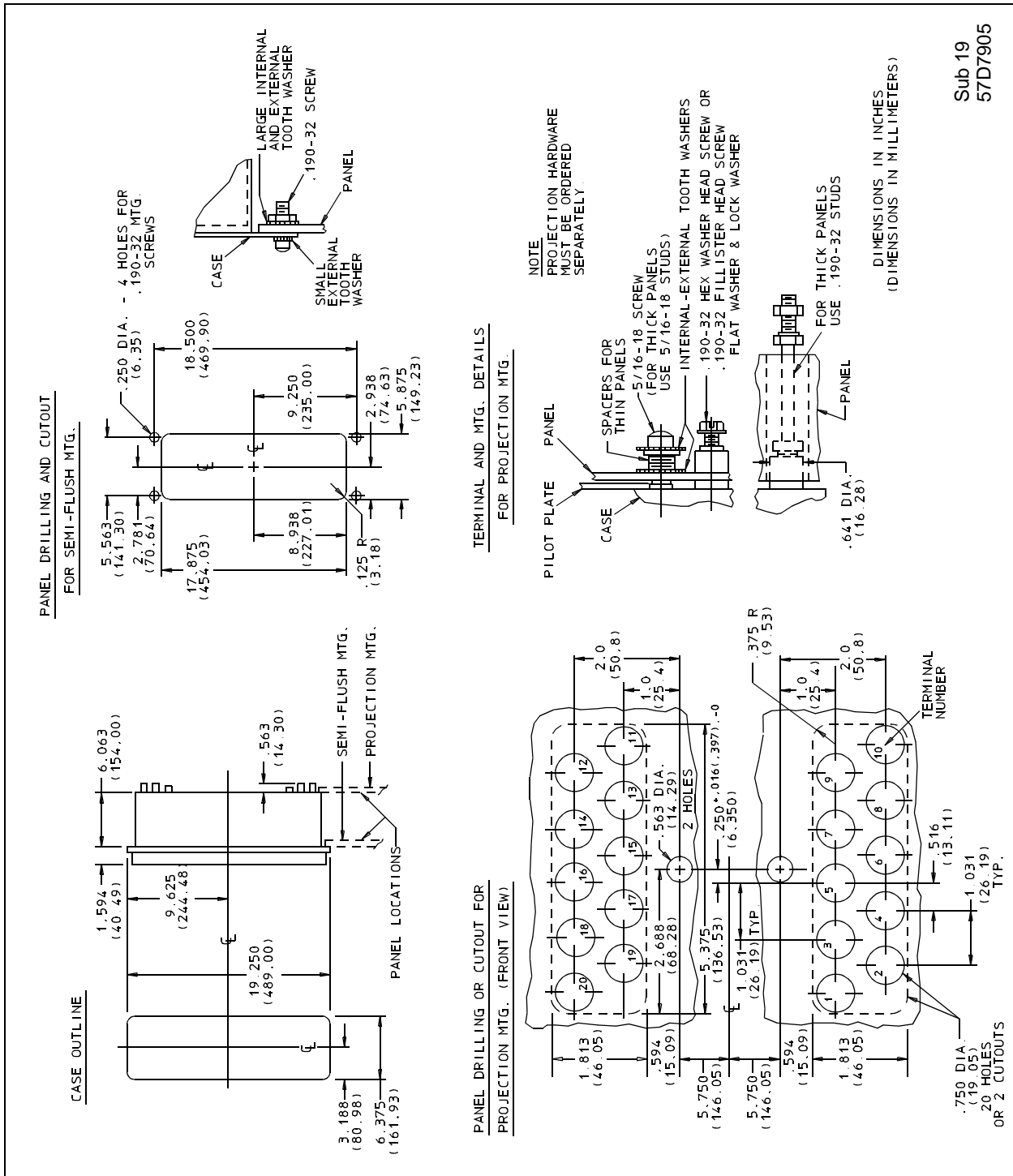

Figure 30: Outline and Drilling Plan for KD-10 and KD-11 in FT-42 Case



ABB Automation Inc.
 4300 Coral Ridge Drive
 Coral Springs Florida 33065
 TEL: 954-752-6700
 FAX: 954-345-5329