

amee  2017

AN INTERNATIONAL ASSOCIATION FOR MEDICAL EDUCATION

26-30 AUGUST 2017
HELSINKI, FINLAND

MESSUKESKUS EXPO AND
CONVENTION CENTRE

AMEE 2017
MARKET PLACE
PROSPECTUS



CONTENTS

WELCOME TO AMEE 2017	2
• Invitation to Participate	
• What is AMEE?	
• AMEE 2017: Helsinki	
• Who Should Exhibit at AMEE 2017?	3
• AMEE 2017 Participants	
• Hotel Accommodation	
AMEE 2016 STATISTICS	4
AMEE 2017 MARKET PLACE SCHEDULE (TENTATIVE)	5
EXHIBITION PACKAGES	
▪ Premium & Standard Commercial	6
▪ Premium & Standard Not-for Profit Organisation	7
▪ Academic Member & Non-Member	8
EXHIBITION SHELL SCHEME BOOTHS & POSTER BOARD STANDS	
▪ Premium & Standard Commercial	9
▪ Premium & Standard Not-for-Profit	10
▪ Academic Member & Non-Member	11
AMEE 2017 MARKET PLACE FLOOR PLAN (TENTATIVE)	12
SPONSORSHIP OPPORTUNITIES – DELEGATE COLLATERAL	13
CONFERENCE SPONSORSHIP & ADVERTISING OPPORTUNITIES	14
WHAT'S NEW FOR THE AMEE 2017 MARKET PLACE?	15
TERMS & CONDITIONS	16
EXHIBITOR APPLICATION PROCESS	17

INVITATION TO PARTICIPATE

The Association for Medical Education in Europe (AMEE) is delighted to invite you to exhibit at the AMEE 2017 annual conference on 27-30 August 2017. AMEE is pleased to offer space to commercial, not-for-profit and academic exhibitors wishing to take advantage of the AMEE conference as a way to engage with participants from around the world. We look forward to welcoming back our much-valued 'regular' exhibitors and to meeting new exhibitors.

WHAT IS AMEE?

AMEE is a worldwide organisation with members in 90 countries on five continents. Members include teachers, educators, researchers, administrators, curriculum developers, deans, assessors, students and trainees in medicine and the healthcare professions.

AMEE promotes excellence in medical education internationally by:

- Promoting the sharing of information through networking, conferences, publications and online activities.
- Identifying improvements in traditional approaches and supporting innovation in curriculum planning, teaching and learning assessment and education management.
- Encouraging research in the field of healthcare professions education.
- Promoting the user of evidence-informed education.
- Setting standards for excellence in healthcare professions education.
- Acknowledging achievement both at an individual and an institutional level.
- Recognising the global nature of healthcare professions education.
- Influencing the continuing development of healthcare professions education through collaboration with relevant national, regional and international bodies.

AMEE 2017: HELSINKI

Helsinki, the capital of Finland, is a vibrant seaside city of beautiful islands and great green parks. The city's rhythm is laid back yet, at the same time, refreshingly active in terms of both the number and quality of restaurants and nightclubs. The capital is a compact city easily explored on foot. Design, architecture, culture and shopping are all great exploration angles and large park areas, forests, lakes, and the coastline with numerous islands sprinkled off it, make certain there's no shortage of natural presence. Needless to say, there's something going on in Helsinki every day of the year.

AMEE 2017 will take place at the Messukeskus Expo and Convention Centre which is located just outside Helsinki city centre and is easily accessible by public transport.

The AMEE Market Place will be located in Hall 6 of the Convention Centre. Catering stations will be dispersed throughout the exhibition for service during lunches, breaks and the Welcome Reception.





WHO SHOULD EXHIBIT IN THE AMEE 2017 MARKET PLACE?

The exhibition consists of commercial, not-for-profit and academic exhibitors, including:

- Publishers of medical and basic science textbooks, and books and journals relevant to teachers in medicine and the healthcare professions
- Manufacturers and suppliers of teaching aids, including simulators, computers, mobile technology and eLearning packages; institutions offering a service in medical education e.g. testing, data handling
- Pharmaceutical companies with an involvement in education, allowing them the opportunity to highlight and demonstrate educational resources that they have produced or supported
- Institutions and bodies offering courses for healthcare professionals across the continuum of education
- Institutions responsible for administration or regulation in medicine and the healthcare professions
- Professional bodies and medical schools

HOTEL ACCOMMODATION

Worldspan has reserved a number of hotel rooms in Helsinki for AMEE 2017. The hotels are listed on the AMEE registration site and in the AMEE provisional programme. We have negotiated a best rate guarantee, where possible, in a selection of 3* and 4* hotels. If you need accommodation close to Messukeskus, we have several hotel options available, but we advise booking these early, in order to guarantee availability!

Accommodation can be booked through the registration site, once you have confirmed your exhibition space and been allocated your registration login details. Please note that hotel rooms can be reserved in your company name, until your chosen sales representative has been confirmed to attend. For any queries please contact:

accommodation@worldspan.co.uk.

AMEE 2017 PARTICIPANTS

More than 3,500 participants are expected, from over 90 countries around the world. Participants typically include medical teachers, many of whom are practising doctors, teachers from other healthcare professions, deans and administrators of medical, veterinary medicine, dental and nursing schools, and researchers.

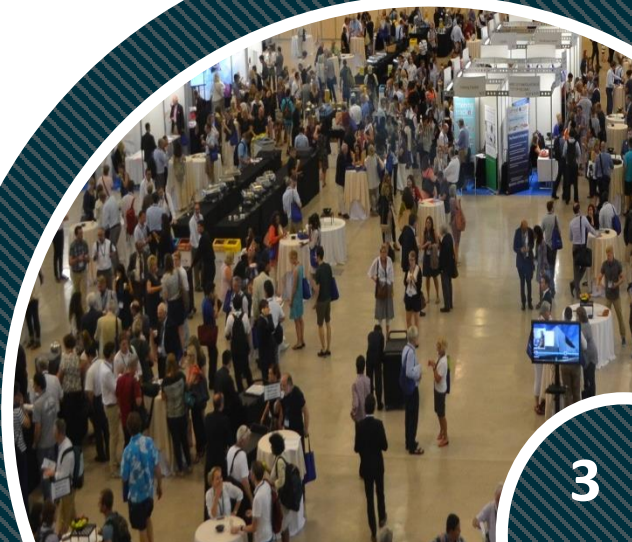

AMEE 2016 STATISTICS

AMEE conferences attract delegates with a variety of educational roles from over 90 countries around the world. Delegate numbers at AMEE conference have continued to increase over the past six years. The statistical diagrams below will provide an overview of the delegate demographic.

DELEGATE NUMBERS

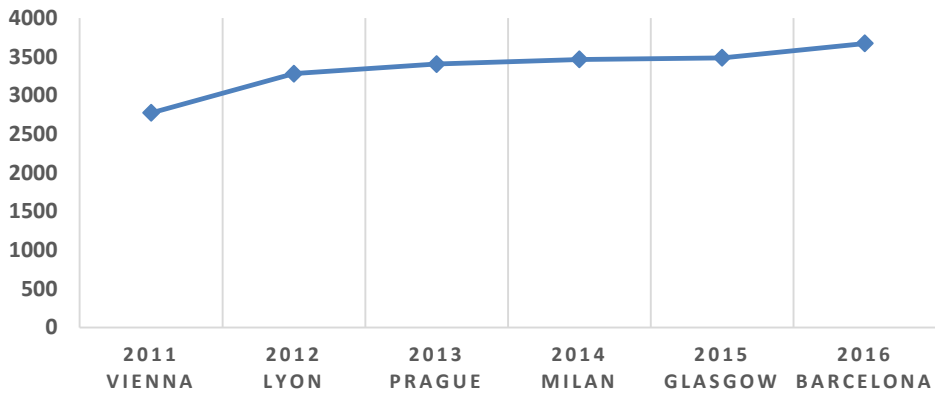

DELEGATE ORIGIN BY CONTINENT

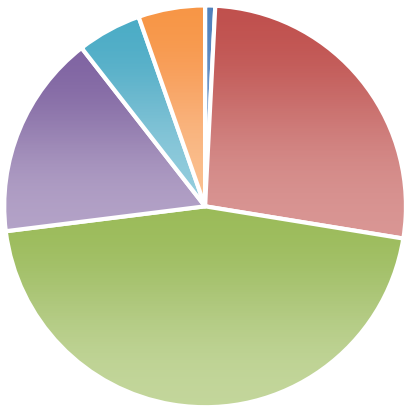

- AFRICA
- ASIA
- EUROPE
- NORTH AMERICA
- OCEANIA
- SOUTH AMERICA

DELEGATE EDUCATIONAL ROLE

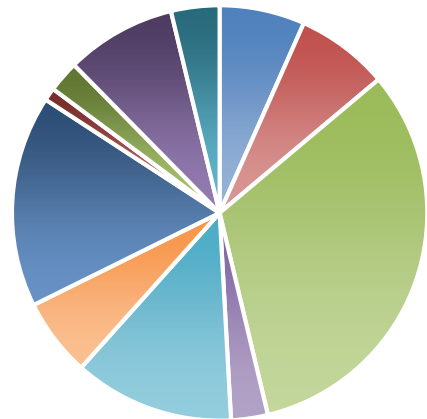

- ADMINISTRATOR
- BASIC SCIENCE TEACHER
- CLINICAL TEACHER
- CME/CPD TUTOR
- HEAD OF INSTITUTION/ACADEMIC DEPARTMENT/UNIT
- MEDICAL STUDENT
- OTHER
- OTHER HEALTHCARE PROFESSIONS STUDENT
- POSTGRADUATE DEAN/VICE DEAN
- POSTGRADUATE TUTOR
- UNDERGRADUATE DEAN/VICE DEAN

AMEE 2017 MARKET PLACE SCHEDULE (TENTATIVE)

The schedule has been provided below. Please note that exact timings may be subject to change and will be reconfirmed before the conference. High delegate traffic has been added in red for your information.

SUNDAY 27 AUGUST	
1300-1630	EXHIBITOR SETUP
18:45 19:15-21:00 21:15	EXHIBITION OPEN NETWORKING RECEPTION EXHIBITION CLOSED
MONDAY 28 AUGUST	
09:30 09:45-10:15 12:00-14:00 15:30-16:00 16:30	EXHIBITION OPEN REFRESHMENT BREAK LUNCH REFRESHMENT BREAK EXHIBITION CLOSED
TUESDAY 29 AUGUST	
09:30 09:45-10:15 12:00-14:00 15:30-16:00 16:30	EXHIBITION OPEN REFRESHMENT BREAK LUNCH REFRESHMENT BREAK EXHIBITION CLOSED
WEDNESDAY 30 AUGUST	
08:00 10:15-10:45 11:00	EXHIBITION OPEN REFRESHMENT BREAK EXHIBITION CLOSED
1100-1600	EXHIBITOR TEAR DOWN

PREMIUM & STANDARD COMMERCIAL PACKAGES

INCLUSIONS	PREMIUM COMMERCIAL €7,000.00	STANDARD COMMERCIAL €6,000.00
Passes	3 full conference passes	2 full conference passes
Plenary Session Logo displayed on PowerPoint slide at start of sessions	✓	✗
Conference Programme Company name, logo, business summary, contact details and weblink listed in the conference programme with an advert at the back of the conference programme.	100-word business summary ½ page advert	50-word business summary ¼ page advert
Conference Website Company name, logo, business summary, contact details and weblink.	100-word business summary	50-word business summary
Conference App Company name, logo, business summary, contact details and weblink listed in the conference app with a banner advert (600 pixels wide x 110 pixels high) shown at the bottom of the screen on rotation with other exhibitor banners.	100-word business summary	50-word business summary
Delegate Bag Insert Single page flyer (maximum size A4)	✓	✗
Onsite Documents 1 hard copy of delegate list and conference programme	✓	✓
Meeting Space Option to book a meeting room for a lunchtime session or evening reception	✓	✗
Exhibition Space 9sqm shell scheme booth	✓	✓

ADDITIONAL NOTES

- Full Conference Delegate Passes include entry to conference sessions and Exhibition Hall, refreshments, lunches and attendance at the opening ceremony/reception. Exhibition Hall Passes allow access to the Exhibition Hall only. All company representatives must be in possession of an Exhibition Hall Pass or Full Conference Delegate Pass to have access to the Exhibition Hall. Additional Exhibitor Hall Passes can be purchased during online registration at a cost of €465.00.
- Delegate bag inserts must be produced and shipped (via Niemi Palvelut Oy – Niemi Services Ltd) by the exhibitor at their own expense. Bag inserts can be added to your package at a cost of €1,000.00 during your online registration, if they are not already included within your preferred package.
- The delegate list will consist of those delegates who have opted to receive communication. It will be provided within your exhibition pack during onsite registration. We are unable to provide the delegate data electronically, due to data sharing laws.
- Meeting room bookings will be managed on a first-come, first-served basis. Additional services such as audio visual equipment and catering are at the exhibitor's own expense.
- For more details about shell scheme booths, please refer to page 9.

PREMIUM & STANDARD NOT-FOR-PROFIT PACKAGES

INCLUSIONS	PREMIUM NOT-FOR-PROFIT €2,000.00	STANDARD NOT-FOR-PROFIT €1,500.00
Passes	1 full conference pass	1 exhibition hall pass
Conference Programme Company name, logo, business summary, contact details and weblink.	50-word business summary	25-word business summary
Conference Website Company name, logo, business summary, contact details and weblink	50-word business summary	25-word business summary
Conference App Company name, logo, business summary, contact details and weblink	50-word business summary	25-word business summary
Delegate Bag Insert Single page flyer (maximum size A4)	✓	✗
Onsite Documents 1 hard copy of the delegate list and conference programme	✓	✓
Exhibition Space 4sqm shell scheme booth	✓	✓

ADDITIONAL NOTES

- Full Conference Delegate Passes include entry to conference sessions and Exhibition Hall, refreshments, lunches and attendance at the opening ceremony/reception. Exhibition Hall passes allow access to the Exhibition Hall only. All company representatives must be in possession of an Exhibition Hall pass or Full Conference Delegate Pass to have access to the Exhibition Hall. Additional Exhibitor Hall passes can be purchased during online registration at a cost of €465.00.
- Delegate bag inserts must be produced and shipped (via Niemi Palvelut Oy – Niemi Services Ltd) by the exhibitor at their own expense. Bag inserts can be added to your package at a cost of €1,000.00 during your online registration, if they are not already included within your preferred package.
- The delegate list will consist of those delegates who have opted to receive communication. It will be provided within your exhibition pack during onsite registration. We are unable to provide the delegate data electronically, due to data sharing laws.
- For more details about the shell scheme booths, please refer to page 10.

ACADEMIC MEMBER & NON-MEMBER PACKAGES

INCLUSIONS	ACADEMIC MEMBER €550.00	ACADEMIC NON-MEMBER €850.00
Conference Programme Institution name and contact details	✓	✓
Conference Website Institution name and contact details	✓	✓
Conference App Institution name and contact details	✓	✓
Exhibition Space Poster Board Stand	✓	✓

ADDITIONAL NOTES

- Academic stands are intended for conference participants who wish to promote their institution through a table/poster board display in the exhibition. They are only available to those paying a full delegate registration or a special rate registration. All institutional representatives wishing to be at the stand must be registered. If the registered participant wishes to have support from a non-registered participant, additional Exhibition Hall only passes may be purchased for €325.00.
- Delegate bag inserts can be added to the package at a cost of €1,000.00 during online registration. The inserts must be produced and shipped (via Niemi Palvelut Oy – Niemi Services Ltd) by the exhibitor at their own expense.
- For more details about the poster board stands, please refer to page 11.

PREMIUM & STANDARD COMMERCIAL SHELL SCHEME

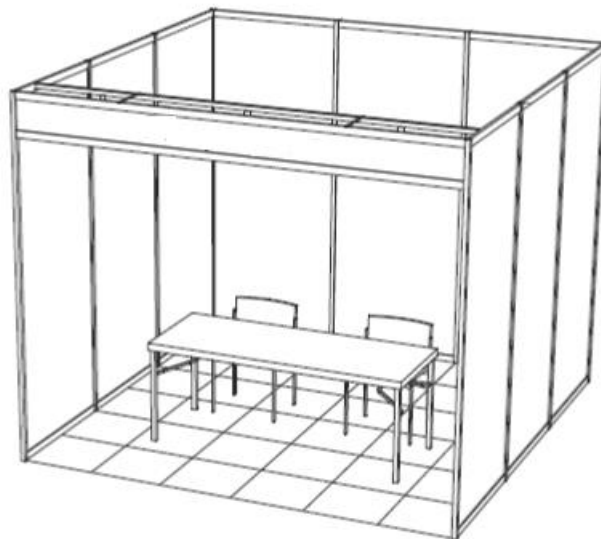
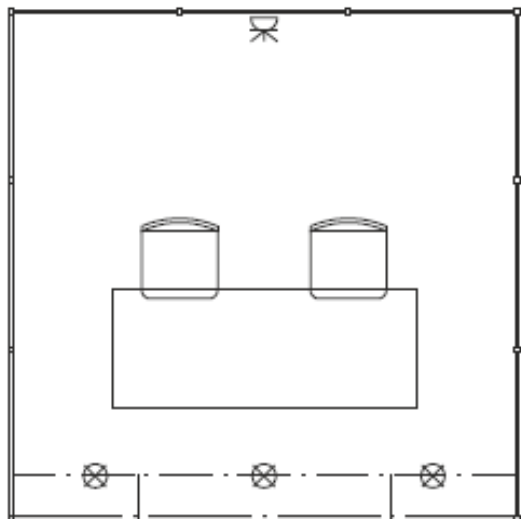

SHELL SCHEME BOOTH (9sqm)

- 3m (l) x 3m (w) x 2.5m (h) white booth walls
- White fascia board with black medium Helvetica text (15 characters maximum)
- 1 spotlight per metre (facing the main aisle) & 1 spotlight on fascia board
- 16A 3.6kw power socket with three outlets
- Blue carpet tiles
- Pre-inauguration cleaning
- 1 x rectangular white table 180cm (l) x 70cm (w) x 70cm (h)
- 3 x dark grey chairs (Premium Commercial) or 2 x chairs (Standard Commercial)
- WiFi

ADDITIONAL NOTES

- Image is for example only. The number of open sides depends on booth location and colour of items may vary.
- WiFi is provided free of charge to all delegates and exhibitors. Please note that if you rely on a high-speed Internet connection to show software or videos at your booth, we recommend purchasing a hard-wired Internet line to guarantee a high quality connection.

PREMIUM & STANDARD NOT-FOR-PROFIT SHELL SCHEME

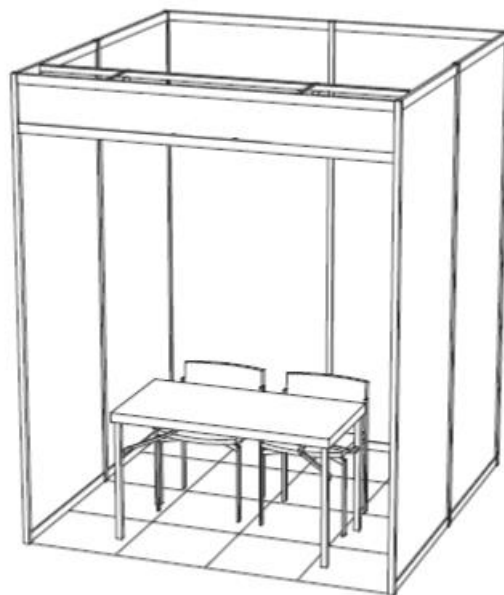
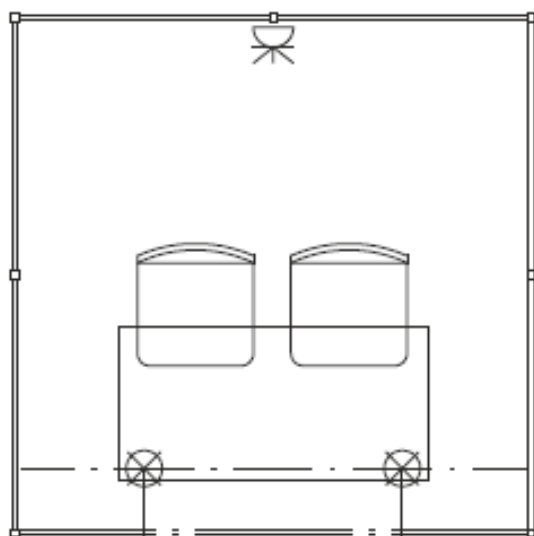

SHELL SCHEME BOOTH (4sqm)

- 2m (l) x 2m (w) x 2.5m (h) white booth walls
- White fascia board with black medium Helvetica text (15 characters maximum)
- 1 spotlight per metre (facing the main aisle) & 1 spotlight on fascia board
- 16A 3.6kw power socket with three outlets
- Blue carpet tiles
- Pre-inauguration cleaning
- 1 x rectangular white table 120cm (l) x 60cm (w) x 60cm (h)
- 2 x dark grey chairs
- WiFi

ADDITIONAL NOTES

- Image is for example only. The number of open sides depends on booth location and colour of items may vary.
- WiFi is provided free of charge to all delegates and exhibitors. Please note that if you rely on a high-speed Internet connection to show software or videos at your booth, we recommend purchasing a hard-wired Internet line to guarantee a high quality connection.

ACADEMIC MEMBER & NON-MEMBER STANDS

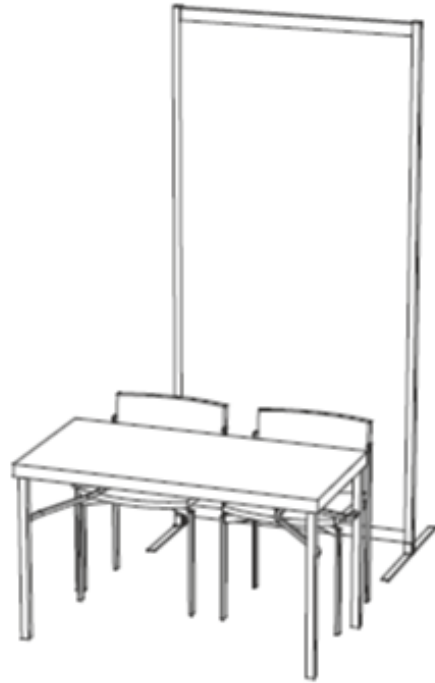
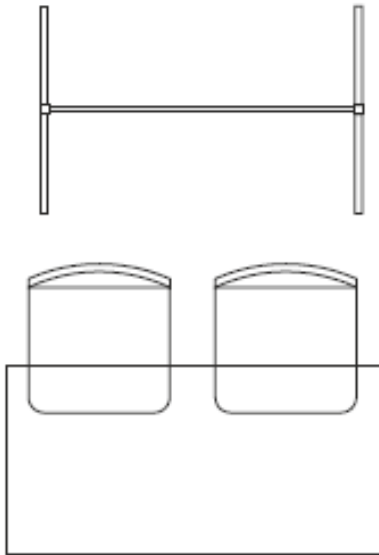

POSTER BOARD STAND

- 220cm (h) x 103cm (w) fabric poster board (attach items with pins etc.)
- Organisation/institution name in black medium Helvetica text (15 characters maximum)
- 1 x rectangular grey table 120cm (l) x 60cm (w) x 60cm (h)
- 2 x dark grey chairs
- WiFi

ADDITIONAL NOTES

- Image is for example only. The number of open sides depends on booth location and colour may vary.
- WiFi is provided free of charge to all delegates and exhibitors. Please note that if you rely on a high-speed Internet connection to show software or videos at your stand, we recommend purchasing a hard-wired Internet line to guarantee a high quality connection.
- No carpet or power supply is included with this stand.

AMEE 2017 MARKET PLACE FLOOR PLAN (TENTATIVE)

The AMEE 2017 floor plan is shown below for you and has been tailored, based on the feedback received from the AMEE 2016 exhibitors. The exhibition hall has been separated into different themed areas and you will be allocated a booth based on the theme that best describes your company/organisation e.g. simulation.



ADDITIONAL NOTES

- Highball tables will be scattered throughout the exhibition area.
- Organisers will allocate exhibition booths/stands on a first-come, first-served basis.
- Due to the nature of AMEE 2017, please note that the floor plan is subject to change.

SPONSORSHIP OPPORTUNITIES – DELEGATE COLLATERAL

Your company can sponsor items given to all delegates at registration. This will provide your company with a great opportunity to get your brand recognised. Further details about the artwork specifications and deadlines will be provided upon confirmation of sponsorship.

DELEGATE CONFERENCE BAGS: 1 SPONSORSHIP AVAILABLE

There are two sponsorship options for the conference delegate bags, depending on how much information you would like to share with the delegates. Both options would be printed onto one side of the bag, with the AMEE conference logo and details displayed on the other.

COMPANY DETAILS & LOGO - €11,000.00

LOGO ONLY - €10,000.00

DELEGATE BAG INSERTS: LIMITED AVAILABILITY

Your company or product flyer can be included within the delegate conference bags. Inserts must be a single A4 (maximum size) page flyer, but can be printed on both sides. The production and shipping costs for the flyers are at the exhibitor's own expense.

BAG INSERTS - €1,000.00

DELEGATE PENS: 1 SPONSORSHIP AVAILABLE

Your company logo can be printed (one colour) onto the pens distributed within the delegate bags.

Plastic Ballpoint Pens - €3,000.00

Metal Ballpoint Pens - €4,000.00

DELEGATE LANYARDS: 1 SPONSORSHIP AVAILABLE

Sponsorship of the lanyards can either be exclusive, showing only your company logo, or be partnered with AMEE. If partnering with AMEE, your company logo would be displayed alternately with the AMEE logo.

EXCLUSIVE - €10,000.00

PARTNERED - €5,000.00

DELEGATE PAPER PADS: 1 SPONSORSHIP AVAILABLE

Your company logo and details can be printed (full colour to one position) onto each page of the paper pads distributed within the delegate bags.

A5 Paper Pad - €3,000.00

A4 Paper Pad - €4,000.00

ADDITIONAL NOTES

- The items above will be available on a first-come, first-served basis.
- The costs displayed above include the cost for production, unless otherwise stated.
- Artwork must be provided by the sponsor in the correct format by the specified deadlines. Any artwork alterations would be at the expense of the sponsor.

CONFERENCE SPONSORSHIP & ADVERTISING OPPORTUNITIES

There are a number of additional sponsorship and advertising opportunities available. The options listed below will allow you to increase your company and brand presence during the AMEE 2017 conference. Further details about the artwork specifications and deadlines will be provided upon confirmation of sponsorship.

COFFEE BREAKS: UP TO 2 SPONSORSHIPS AVAILABLE

Delegate catering will be held in the Exhibition and Poster Hall during the AMEE conference. Sponsorship of the coffee breaks would include banner stands detailing your company information being displayed at catering stations. Tent cards featuring your company logo would also be sited on the highball tables scattered throughout the hall.

One Day - €6,000.00

Entire Event - €13,500.00

PLENARY SEAT DROPS: 4 OPPORTUNITIES AVAILABLE

Hall 1 at the Messukeskus will host the main plenary sessions and accommodates 4,373 seated delegates. This year AMEE would like to offer a limited number of seat-drops to exhibitors, to help get your company information directly into the delegates' hands. The cost of leaflet production is the responsibility of the exhibitor and enough copies must be provided for the entire capacity of the Auditorium.

SEAT DROPS - €3,000.00

INTERNET CAFÉ: 1 SPONSORSHIP AVAILABLE

Sponsorship of the Internet Café will provide a brilliant branding opportunity for your company. Your advert (subject to approval by AMEE) will feature on banner stands within the Internet Café area.

INTERNET CAFÉ - €6,700.00

WEBSITE ADVERT: LIMITED NUMBER OF SPONSORSHIPS AVAILABLE

Website advertising is available on the MedEdWorld website (<http://www.mededworld.org/home.aspx>). Please contact Worldspan if you are interested in this opportunity and an information pack will be sent to you.

ADDITIONAL NOTES

- The items above will be available on a first-come, first-served basis.
- The costs displayed above include the cost for production, unless otherwise stated.
- Artwork must be provided by the sponsor in the correct format by the specified deadlines. Any artwork alterations would be at the expense of the sponsor.

WHAT'S NEW FOR THE AMEE 2017 MARKET PLACE?

ORIENTATION SESSIONS OF THE AMEE MARKET PLACE

Orientation sessions will be held in the AMEE Market Place on each day of the conference. Each orientation session will take delegates on a guided tour of one of the themed exhibitor areas within the AMEE Market Place. The guide will provide a summary about each exhibiting company within that themed area.

Exhibitor representatives can provide further details about their company/products, or a brief demonstration, provided a speaking slot has been booked for the orientation session. You will be given the opportunity to register your interest for a speaking slot during your online registration. Each orientation session will be fully advertised in the conference programme.

SOAPBOX SLOTS

All exhibiting companies and organisations are invited to 'get on your soapbox' at AMEE 2017. Soapbox slots for the central stage within the AMEE Market Place will be available to all exhibitors. The speaking slots (10 minute duration) will take place during refreshment breaks and lunchtime when delegate traffic is at its highest.

Limited spaces are available and will be allocated on a first-come, first-served basis, so please book your slot during online registration, to avoid disappointment.

COMPETITIONS

INCREASE DELEGATE TRAFFIC TO YOUR STAND!

Offering a great prize for delegate participation in a competition is a fantastic way to increase the number of visits to your booth. If you are interested in running a competition, please provide all details to the AMEE exhibition team for approval. All competitions taking place in the AMEE Market Place will be advertised on a dedicated page within the AMEE website and conference app. Please note that it is the exhibitor's responsibility to fully run the competition and ensure that the winning delegate receives their prize.

SOCIAL DINNER

ARE YOU INTERESTED IN HOSTING A SOCIAL DINNER DURING THE AMEE CONFERENCE?

Worldspan can help you to organise private offsite dinners upon request. Please contact Chantel Courtney (exhibitions@worldspan.co.uk) for further information.

TERMS & CONDITIONS

The terms and conditions set out below relate to the exhibition for the AMEE 2017 conference, taking place in Helsinki, Finland.

APPLICATIONS

Exhibition packages and sponsorship opportunities are available on a first-come, first-served basis, as are all elements of the packages. Worldspan should receive all exhibition registrations by **31 July 2017** at the latest. Payment of exhibition fees should be made by **31 July 2017**.

CANCELLATION

All cancellations must be made in writing no later than **30 June 2017** and are subject to a 15% cancellation fee. After **1 July 2017** no refunds can be given. Please note that, in the event of cancellation, all bank or credit card charges incurred by AMEE will be charged on to the exhibitor.

EXHIBITOR DETAILS

Supply of logos, company information and adverts for the conference website, app and programme is the responsibility of the exhibitor. If files are not received in the required format, or by the stated deadline, the meeting organisers bear no responsibility and any cancellations will be subject to the fees mentioned above.

SHIPPING

All exhibitors are required to make their own arrangements for shipping/handling. Shipping information can be found on the exhibition website. Shipping instructions must be followed and packages labelled properly to avoid any delay in locating your packages on-site, which can result in your leaflets being excluded from the delegate bags and equipment arriving to your booth/stand late.

ARTWORK

All artwork should be provided in the correct format and by the deadline stated. The design of artwork and any amendments are the exhibitor's responsibility and subject to approval by AMEE.

ADDITIONAL EQUIPMENT AND SERVICES

Additional equipment and services are available to order from Worldspan during your online registration.

WIFI

No routers are permitted at the AMEE 2017 exhibition. WiFi is provided free of charge to all delegates and exhibitors. Please note that if you rely on a high-speed Internet connection to show software or videos at your booth, we recommend purchasing a hard-wired Internet line to guarantee a high quality connection

VAT

VAT is not applicable.

EXHIBITION APPLICATION PROCESS

The exhibition website has been redesigned for AMEE 2017 to improve your registration experience. You can now choose your booth location and provide all of your booth details online to streamline the process. Please note that you can log back into your registration account at any time to complete the finer details but you must continue to the end of the registration in order to complete your exhibition booking and confirm your booth location.

To register for an AMEE 2017 exhibition package, please follow the link below to complete your registration online. Please note that you must choose a booth within the area allocated to your company theme, e.g. simulation. All booths will be allocated on a first-come, first-served basis.

<https://www.etches.com/amee2017exhibition>

Once you have completed your registration, you will receive a confirmation email and your login details for the exhibition website.

Should you need any assistance during your registration, please contact the AMEE exhibition team at exhibitions@Worldspan.co.uk.

EXHIBITION MANAGEMENT

AMEE is pleased to once again be working with Worldspan Plc who are managing Exhibition and Sponsorship opportunities for AMEE 2017.

Please direct all enquiries regarding Exhibitions and Sponsorship to Worldspan Plc.

Contact: Chantel Courtney (Exhibition Logistics)

Telephone: +44 (0) 1745 828400

Email: exhibitions@worldspan.co.uk

amee  2017

AN INTERNATIONAL ASSOCIATION FOR MEDICAL EDUCATION

26-30 AUGUST 2017
HELSINKI, FINLAND

MESSUKESKUS EXPO AND
CONVENTION CENTRE

Exhibition Management

Contact: Chantel Courtney (Exhibition Logistics)

Telephone: +44 (0) 1745 828400

Email: exhibitions@worldspan.co.uk