

Consequences of Out-of-Phase Reclosing on Feeders With Distributed Generators

Dale Williston, *Williston & Associates Inc.*
Dale Finney, *Schweitzer Engineering Laboratories, Inc.*

Abstract—As the penetration of distributed generation continues to increase, questions about the adequacy of anti-islanding schemes remain. Failure to detect the formation of an island raises the concern of out-of-phase reclosing. Such an event can potentially cause damage to utility equipment and nearby customer equipment, as well as the distributed generator itself. This paper assesses the probability of an out-of-phase reclosing event and identifies and quantifies the stress to the various elements that make up the distribution network. The analysis is compared with relevant standards and guidelines. As a result, the reader will gain better insight into the requirements for anti-islanding.

I. INTRODUCTION

This paper examines the potential for damage to electrical equipment as a result of a reclosing operation in a distribution network that includes distributed generation (DG). The need to address future energy requirements through more environmentally friendly technologies has led to an increase and even an acceleration of the penetration of DG. As DG penetration grows, the need to understand this contingency becomes increasingly relevant.

This paper identifies the events leading up to a DG reclosing event. It considers the various types of equipment found in the network and analyzes the potential for damage for each type of equipment. The analysis is compared with relevant standards and guidelines. This paper also identifies methods to mitigate the possibility of a reclosing event.

II. DG ISLANDING

In the past, a distribution network consisted of radial feeders emanating from a substation. Passive loads were connected along the length of the feeder. In addition, there could be a midline recloser on the feeder. A feeder had a single source—the substation. De-energizing the feeder entailed opening the feeder breaker. The addition of a generator into the network changed the situation. Consider the network shown in Fig. 1, which depicts a distribution feeder with a recloser. An aggregate load and a generator are located downstream of the feeder. If the recloser opens, then the generator may continue to supply power to the load. This is known as an island.

In general, islanding is not permitted for a number of reasons. First, islanding represents a possible safety hazard for operations personnel. A worker may conclude that the circuit downstream from the open switch is de-energized and therefore safe to work on. Studies into this risk concluded that it can be adequately addressed by following standard approved

work practices. A second issue is power quality. The utility is responsible for maintaining a high level of power quality to its customers. During an islanding event, the quality of power supplied to customers within the island is not controlled by the utility. Third, restoring the connection to the grid introduces the possibility of equipment damage. This third issue is the focus of this paper.

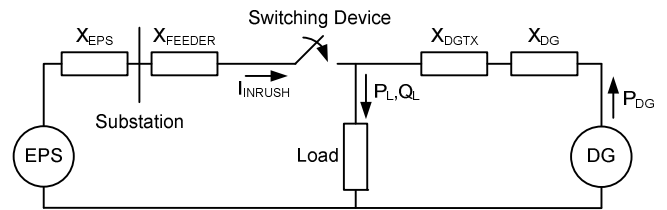

Fig. 1. Feeder with a distributed generator

III. RECLOSING SCENARIOS

A. Reclosing After a Fault

Transient faults can account for 80 to 90 percent of the faults in a distribution network. The protection applied at the substation breaker and at the recloser typically includes a feature known as autoreclose. The autoreclose function improves the supply availability to customers on the feeder by automatically closing the breaker after it has tripped because of a fault. The IEEE 1547 Standard for Interconnecting Distributed Resources With Electric Power Systems recommends disconnecting or tripping the DG within 2 seconds following the islanding condition. However, utilities often prefer autoreclose times in the order of 0.5 seconds. It is important to note that autoreclose is initiated by protection functions and not a manual operation of the substation breaker or recloser. Therefore, an autoreclose operation occurs only after there has been a fault on the feeder. IEEE 1547 Section 4.2.1 states, “The DR [distributed resource] unit shall cease to energize the Area EPS [electric power system] for faults on the Area EPS circuit to which it is connected” [1]. This means that the DG is also required to disconnect for the feeder fault. The interconnect protection located at the DG is responsible for detecting feeder faults. Setting the interconnect protection requires a fault study. The requirement to detect feeder faults may confer some restrictions on the DG design. However, it is reasonable to conclude that in a properly designed system, reclosing onto a connected DG after a fault is possible only in an instance where the DG interconnect protection is unavailable or the DG breaker fails to operate.

B. Manual Operation or Control Problem

A reclosing event could also occur if the feeder breaker or a recloser were inadvertently opened without first disconnecting the downstream DG. Following the formation of the island, the breaker is reclosed. It is conceivable that a fault in the control circuitry of the feeder breaker or recloser could produce the same result. IEEE 1547 Section 4.4.1 states, “For an unintentional island in which the DR energizes a portion of the Area EPS through the PCC [point of common coupling], the DR interconnection system shall detect the island and cease to energize the Area EPS within two seconds of the formation of an island” [1].

One way to comply with this clause is to ensure that the DG cannot supply enough power to the load within the island. Most utilities employ a two-to-one rule—meaning that the minimum islanded load must be twice as large as the DG rating [2]. As a result, it is impossible to match load and generation within the island, and the island is not sustainable.

For a higher-penetration DG application, it may be difficult or impossible to ensure a significant mismatch between load and generation within the island. Anti-islanding schemes are applied to ensure that DG does not remain connected. Several schemes can be employed, such as the following:

- Passive anti-islanding schemes detect an islanding event by measuring power system signals, such as voltage or frequency, at the DG. Passive schemes have been shown to have a nondetection zone [3]. In other words, if the real and reactive power flow through the islanding breaker was zero at the instant prior to opening, then passive schemes are not guaranteed to operate. However, studies have shown that passive schemes can operate for a power mismatch in the range of a few percent of the DG kVA rating [4].
- Active anti-islanding schemes are generally applicable only to inverter-based DG. Typically, these schemes introduce an intentional positive feedback in order to destabilize the inverter controls. Consequently, the inverter cannot regulate voltage or frequency at nominal values when disconnected from the grid. These schemes are arguably more effective than passive schemes in that their nondetection zones are smaller or zero.
- Transfer tripping entails sending a trip signal to the DG when the upstream breaker opens. Because the DG is remotely located, a communications system is required. In addition, every upstream interrupter that can island the DG must send a transfer trip signal. These schemes are further complicated if tie switches can transfer the DG from one feeder to another.

In summary, reclosing due to manual operation and/or faulty control is possible only on systems where sustained islanding is possible and only if the anti-islanding scheme has failed.

IV. RECLOSING INRUSH CURRENT

Once the breaker has opened, the DG supplies the local load on the feeder. The DG controls should be configured such that they cannot actively regulate voltage or frequency. As a result, any small mismatch in the load and generation (either real or reactive power) causes the voltage magnitude and/or angle to deviate from the grid voltage. Subsequently, a significant voltage develops across the open breaker. The voltage across the breaker is given by (1).

$$V_{BKR} = \sqrt{|V_{EPS}|^2 + |V_{DG}|^2 - 2 \cdot |V_{EPS}| \cdot |V_{DG}| \cdot \cos(\delta)} \quad (1)$$

where:

δ is the angle between the grid voltage and the DG voltage.

Fig. 2 shows a plot of breaker voltage versus angle.

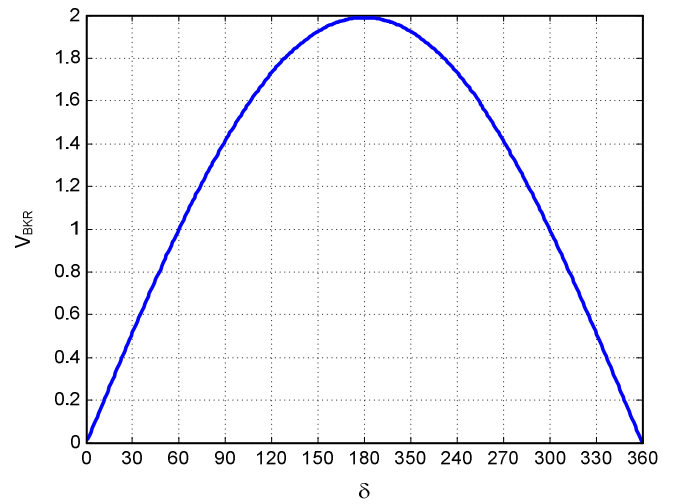

Fig. 2. Breaker voltage versus angle ($V_{DG}, V_{GRID} = 1$ per unit [pu])

Note that if the voltage magnitudes are held constant at 1 pu, when the angle reaches 60 degrees, the breaker voltage is 1 pu, and at 180 degrees, the breaker voltage is 2 pu. When the device closes again, this voltage drives an inrush current, which flows between the grid and the DG.

We can make an estimation about a likely angle for an out-of-phase autoreclose event. We assume that islanding occurs because of a fault, that DG protection fails to detect the fault, and that the power mismatch results in a frequency just less than the pickup of the underfrequency element. IEEE 1547 specifies tripping at 59.3 Hz within 0.16 seconds for generators less than 30 kW. If we assume an autoreclose time of 0.5 seconds, then the angular difference at reclosing is:

$$(60 - 59.3) \text{ Hz} \cdot 360^\circ \cdot 0.5 \text{ seconds} = 40.3^\circ \quad (2)$$

A worst-case approach assumes that the angle is 180 degrees. Referring to Fig. 1, the worst-case inrush current ($V_{DG} = V_{EPS} = 1$ pu and $\delta = 180^\circ$) can be calculated using (3) [5] [6].

$$I_{INRUSH} = \frac{2 \cdot V_{EPS}}{Z_{EPS} + Z_{FEEDER} + X_{DGTX} + X_{dDG}''} \quad (3)$$

where:

Z_{EPS} is the impedance of the area electric power system.

Z_{FEEDER} is the impedance of the feeder supplying the DG.

X_{DGTX} is the reactance of the DG interconnection transformer.

X_{dDG}'' is the subtransient reactance of the DG.

V. DAMAGE POTENTIAL

In general, electrical equipment may be subjected to damage in a number of ways. For instance, insulation is damaged when equipment is operated above its design temperature. This situation is often a result of increased I^2R losses during an overload. Also, in generators, motors, and transformers, an overvoltage condition causes core saturation. The resulting eddy currents lead to damage. The damage potentials for the various components within the distribution network are described in the following sections.

A. Power Transformers

The inrush current is equivalent to a through fault for transformers located between the grid source and the DG, including the substation transformer and the DG step-up transformer. The inrush current produces magnetic forces that cause displacement of conductors, insulation compression, and insulation wear. The effects are cumulative over the life of the transformer.

ANSI/IEEE C57.12.00-1987 specifies the maximum symmetrical short-circuit withstand current [7]. The short-circuit withstand for three-phase transformers less than 500 kVA is given in Table I. For Category II (501 to 1,667 kVA), the short-circuit withstand current is calculated using (4) and neglecting the equivalent system impedance behind the transformer, X_{SYS} . The short-circuit withstand is calculated for larger transformers (Categories III and IV) using (4) and considering both the transformer and system impedances.

$$I_{WITHSTAND} = \frac{I_{RATED}}{X_{TX} + X_{SYS}} \quad (4)$$

Table 13 of the standard provides guidance on system impedance in the event that these data are unavailable.

TABLE I
CATEGORY I SHORT-CIRCUIT WITHSTAND CAPABILITY [7]

Single-Phase kVA	Three-Phase kVA	Withstand Capability in pu of Base Current (Symmetrical)
5 to 25	15 to 75	40
37.5 to 110	112.5 to 300	35
167 to 500	500	25

B. Circuit Breakers and Reclosers

One of the primary ratings of a circuit breaker or recloser is its interrupting rating. This value is expressed in amperes (symmetrical) at maximum rated voltage. For example, single-phase reclosers can have an interrupting rating that ranges from 1,250 A (for a 50 A recloser) to 12,500 A (for an 800 A recloser). Interrupters that are located between the grid source and DG are exposed to the inrush current defined by (3), and this current produces mechanical forces within the interrupter. In addition, the circuit breaker or recloser that forms the open point between the grid and the island is subjected to up to 2 pu voltage across the open contacts, as illustrated in Fig. 2. This situation is equivalent to that of the synchronizing breaker in a power plant. Breaker flashovers are known to occur when synchronizing a generator, and as a result, such breakers are often equipped with a modified breaker failure scheme [8]. IEEE C37.04-1999 specifies an out-of-phase switching current capability for circuit breakers [9]. It should be noted that it is not considered necessary to include this specification for all applications. It applies only to circuit breakers that will be used to connect two parts of the system during an out-of-phase condition, for instance, the synchronizing breaker at a generating station. If specified, the preferred rating is 25 percent of rated (symmetrical) short-circuit rating of the breaker [9]. Evidently, there are no similar ratings for reclosers.

C. Distributed Generators

IEEE C50.12 and C50.13 list the requirements for large synchronous generators. NEMA MG1 covers smaller generators. These documents caution against poor synchronizing because of the resulting high values of current and torque. A maximum breaker closing angle of ± 10 degrees is specified. The high transient torque can cause a coupling failure. It can also cause the coil/bar insulation to crack [10].

The standards require that a generator be designed to withstand a three-phase short circuit at its terminals while operating at rated load and 1.05 pu rated voltage.

This value of a three-phase short-circuit current is given by:

$$I_{SC} = \frac{V_{DG}}{X_d''} \quad (5)$$

However, it has been shown in [11] that the transient torque can exceed that of a three-phase fault by a factor 2 to 3 times during an out-of-phase synchronization event. This torque imposes mechanical stresses both on the generator and the prime mover. Maximum torque is produced at an angle of 120 degrees rather than the value of 180 degrees that produces maximum inrush current [12].

Consequently, in this paper, we use peak torque rather than inrush current as a measure of damage potential on generators and motors. A computer simulation is used to determine peak values of torque.

D. Loads

Passive loads, such as heating or lighting, connected within the island are unaffected by the inrush current due to out-of-phase reclosing. However, the case of a motor is quite different. During islanding, a motor remains in synchronism with the connected DG. If, at the instant of reclosing, there is an angular shift between the DG and the system, then the motor is subjected to its own torque transient in much the same way that the DG is affected. ANSI C50.41 deals with induction motors within generating plants and defines a limitation for out-of-phase reclosing expressed as a volts-per-hertz value across the open breaker. However, no similar limits are defined for motors outside of generating plants. NEMA MG1 does, however, list values for breakdown torque for small induction motors (see Table II).

TABLE II
BREAKDOWN TORQUE FOR SMALL INDUCTION MOTORS [13]

Horsepower	Breakdown Torque (lb-ft)	
	3,450 rpm	1,725 rpm
1.5	3.6-4.6	6.8-10.1
2	4.6-6.0	10.1-13.0
3	6.0-8.6	13.0-19.0
5	8.6-13.5	19.0-30.0
7.5	13.5-20.0	30.0-45.0
10	20.0-27.0	45.0-60.0

Although there are no strict requirements, some manufacturers do design motors to withstand the torque produced by a fault at the terminals.

An accurate calculation of the torque transient in an induction motor requires that motor speed and trapped flux be taken into account. The estimation of motor transient torque in the examples that follow is determined through computer simulation.

VI. DG RECLOSING ANALYSIS

A. Low-Penetration DG Example

The first example is a 50 kVA generator connected to a 7-mile, 13.1 kV feeder circuit. The parameters of the system are summarized in Table III.

TABLE III
LOW-PENETRATION DG EXAMPLE

EPS Transformer	Voltage = 13.1 kV
	kVA = 10,000 kVA
	Leakage reactance = 10%
	Peak load = 6,000 kVA
Feeder	Z1 = 0.78 + 0.71j Ω/mile
	Z0 = 1.49 + 2.28j Ω/mile
	Length = 7 miles
DG Transformer	Voltage = 13,100/460 V
	kVA = 75 kVA
	Leakage reactance = 7%
Generator	Voltage = 460 V
	kVA = 52 kVA
	X _d , X _d ' , X _d '' = 2.6, 0.19, 0.13 pu
	X _q , X _q ' , X _q '' = 1.2, 0.12, 0.09 pu
	T _d ' , T _d '' , T _q '' = 0.025, 0.006, 0.006 seconds
	H = 0.13 seconds
	F = 0.02 pu
	rpm = 1,800

The penetration factor is:

$$\frac{52 \text{ kVA}}{6,000 \text{ kVA}} = 0.009 \quad (6)$$

Factors below 0.30 are considered low penetration. The rated current of the EPS transformer is:

$$I_{EPS \text{ RATED}} = \frac{10,000 \text{ kVA}}{\sqrt{3} \cdot 13.1 \text{ kV}} = 440 \text{ A} \quad (7)$$

Using (4):

$$I_{EPS \text{ WITHSTAND}} = \frac{440 \text{ A}}{0.1} = 4,400 \text{ A} \quad (8)$$

The network impedances are:

$$Z_{EPS} = \frac{(13.1 \text{ kV})^2}{10 \text{ MVA}} \cdot 10\% = j1.716 \Omega \quad (9)$$

$$Z_{DGTX} = \frac{(13.1 \text{ kV})^2}{0.075 \text{ MVA}} \cdot 7\% = j160 \Omega \quad (10)$$

$$Z_{EP} = \frac{(13.1 \text{ kV})^2}{0.052 \text{ MVA}} \cdot 13\% = j429 \Omega \quad (11)$$

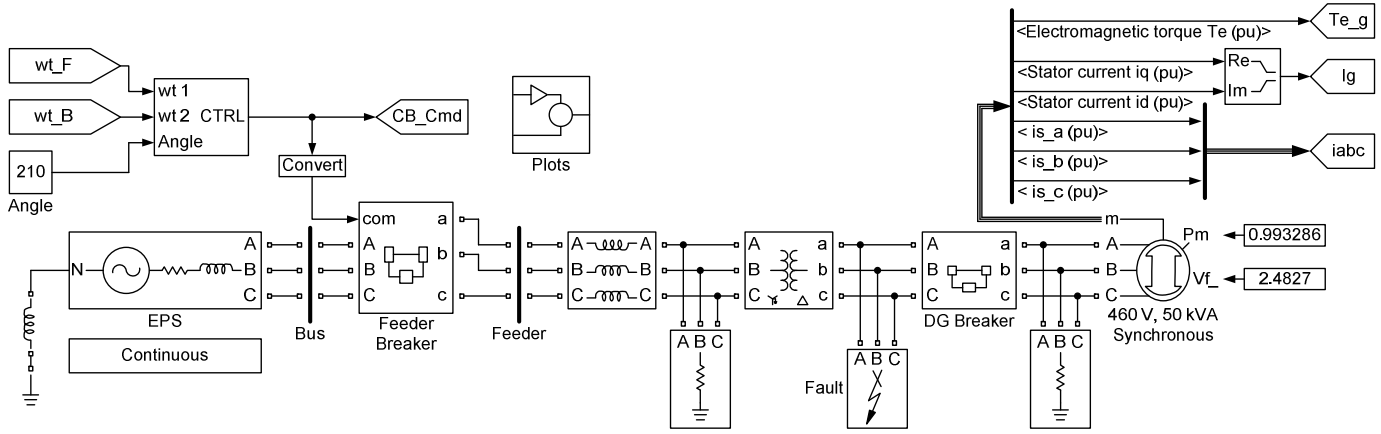

Fig. 3. Low-penetration model

The inrush current associated with an out-of-phase reclose is:

$$I_{\text{INRUSH}} = \frac{2 \cdot 131 \text{ kV}}{j1.76 \Omega + (5.5 + j5) \Omega + j160 \Omega + j429 \Omega} \quad (12)$$

$$I_{\text{INRUSH}} = 44 \text{ A}$$

Clearly, this value is far below the maximum withstand current of the transformer of 4,400 A. This value will also likely be below the interrupt rating of any recloser on the feeder.

The rated current of the DG transformer is:

$$I_{\text{DGTX RATED}} = \frac{75 \text{ kVA}}{\sqrt{3} \cdot 13.1 \text{ kV}} = 3.3 \text{ A} \quad (13)$$

From Table I, the withstand current is:

$$I_{\text{DGTX WITHSTAND}} = 40 \cdot 3.3 \text{ A} = 132 \text{ A} \quad (14)$$

Note that the inrush current is also less than the withstand current of the DG step-up transformer.

MATLAB[®] and Simulink[®] were used to model the system in order to determine the torque seen by the generator. The model allows a fault to be applied at the terminals of the machine. It also allows the feeder breaker to be opened and reclosed. The user can choose the reclosing angles. Fig. 3 shows the Simulink model.

The plot in Fig. 4 is a 5-cycle, three-phase fault at the terminals of the generator.

Fig. 5 shows the electrical torque for a reclose at 120 degrees. Note that it is more than twice the value of the three-phase fault.

We can conclude that only the generator is at risk in this example.

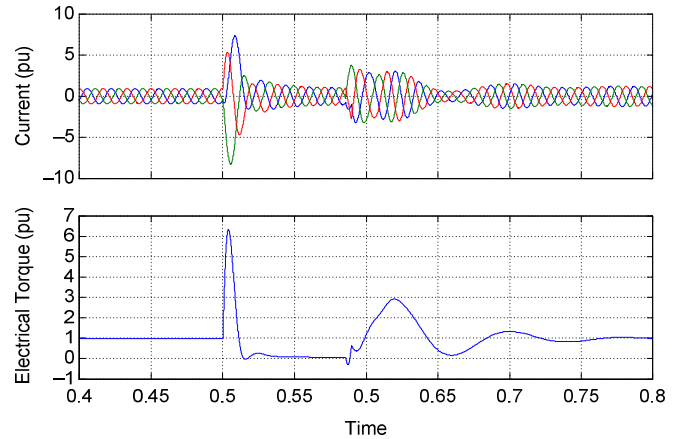

Fig. 4. Low-penetration three-phase fault

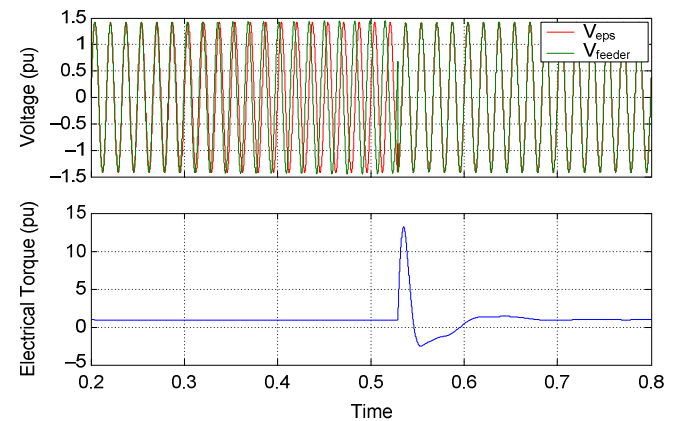

Fig. 5. Low-penetration reclose at 120 degrees

B. High-Penetration DG Example

The second example is a 50 kVA generator connected to a 7-mile, 13.1 kV feeder circuit. The parameters of the system are summarized in Table IV.

TABLE IV
HIGH-PENETRATION DG EXAMPLE

EPS Transformer	Voltage = 13.1 kV
	kVA = 10,000 kVA
	Leakage reactance = 10%
	Peak load = 6,000 kVA
Feeder	$Z_1 = 0.78 + 0.71j \Omega/\text{mile}$
	$Z_0 = 1.49 + 2.28j \Omega/\text{mile}$
	Length = 3.6 miles
DG Transformer	Voltage = 13,100/460 V
	kVA = 3,000 kVA
	Leakage reactance = 7%
Generator	Voltage = 460 V
	kVA = 2,500 kVA
	$X_d, X_d', X_d'' = 2.4, 0.20, 0.15 \text{ pu}$
	$X_q, X_q', X_q'' = 1.77, 0.26, 0.05 \text{ pu}$
	$T_d', T_d'', T_q'' = 0.33, 0.03, 0.03 \text{ seconds}$
	H = 0.347 seconds
	F = 0.009 pu
	rpm = 1,800

The penetration factor is:

$$\frac{2,500 \text{ kVA}}{6,000 \text{ kVA}} = 0.417 \quad (15)$$

This is, therefore, a high-penetration application.

The network impedances are:

$$Z_{\text{DGTX}} = \frac{(13.1 \text{ kV})^2}{3,000 \text{ kVA}} \cdot 7\% = j4 \Omega \quad (16)$$

$$Z_{\text{EPS}} = \frac{(13.1 \text{ kV})^2}{2,500 \text{ kVA}} \cdot 15\% = j10.3 \Omega \quad (17)$$

The inrush current associated with an out-of-phase reclose is:

$$I_{\text{INRUSH}} = \frac{2 \cdot 13,100 \text{ V}}{j1.76 \Omega + (2.8 + j2.5) \Omega + j4 \Omega + j10.3 \Omega} \quad (18)$$

$$I_{\text{INRUSH}} = 1,395 \text{ A}$$

This value is still below the maximum withstand current of the transformer (4,400 A). It may, however, exceed the interrupt rating of a recloser on the feeder.

The rated current of the DG transformer is:

$$I_{\text{DGTX RATED}} = \frac{3,000 \text{ kVA}}{\sqrt{3} \cdot 13.1 \text{ kV}} = 132.2 \text{ A} \quad (19)$$

The withstand current is:

$$I_{\text{DGTX WITHSTAND}} = \frac{132.2 \text{ A}}{0.07} = 1,889 \text{ A} \quad (20)$$

Note that the inrush current is less than the withstand current of the DG step-up transformer.

The model of Fig. 3 was updated with the data from Table IV to produce the plots of Fig. 6 and Fig. 7.

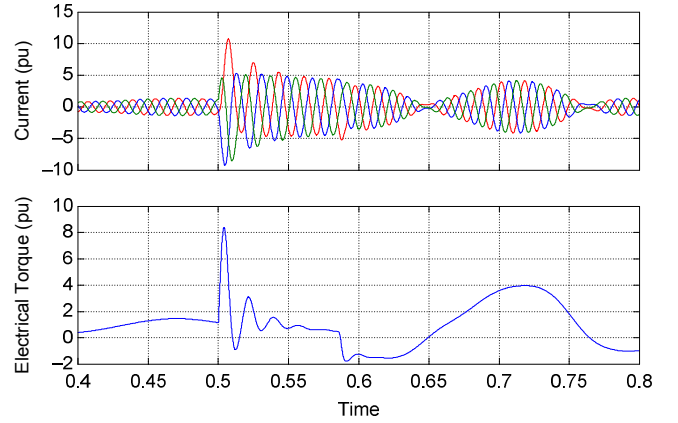

Fig. 6. High-penetration three-phase fault

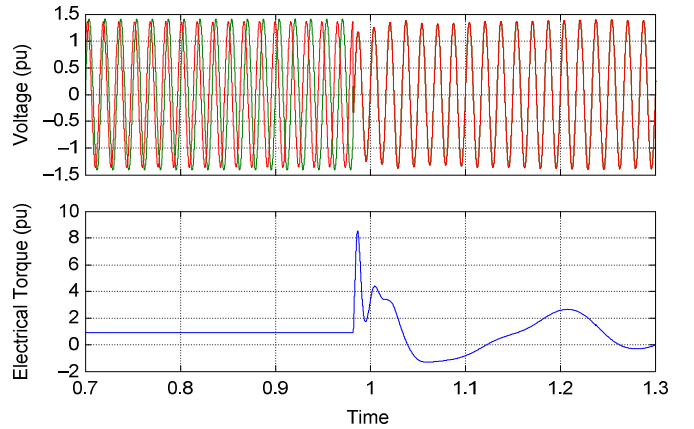

Fig. 7. High-penetration reclose at 120 degrees

In this example, the torques generated from the three-phase fault and the reclosing event are approximately the same.

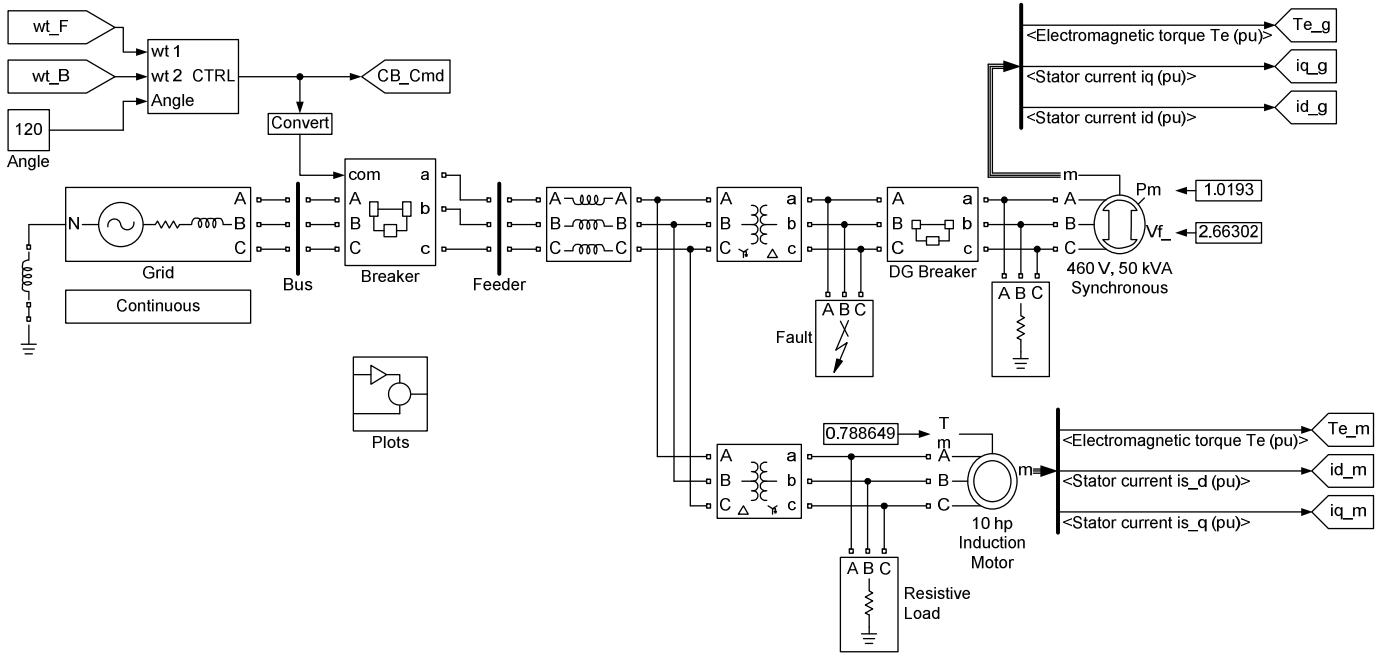

Fig. 8. Low-penetration model with a motor load

C. Impact to a Motor

In order to investigate the impact to motor loads, the model in the low-penetration DG example was modified, as shown in Fig. 8. The details of the induction motor and transformer are given in Table V.

TABLE V
ADDITIONAL DATA FOR THE LOW-PENETRATION EXAMPLE

Induction Motor	Voltage = 575 V
	Horsepower = 10 hp
	Stator resistance = 0.0207 pu
	Stator inductance = 0.04655 pu
	Rotor resistance = 0.01412 pu
	Rotor inductance = 0.04655 pu
	Mutual inductance = 1.577 pu
	Inertia constant = 0.1191 seconds
Rated speed = 1,760 rpm	
Motor Transformer	Voltage = 13,100/575 V
	kVA = 35 kVA
	Leakage reactance = 6%

The base torque for this motor is:

$$T_{\text{BASE}} = \frac{33,000 \cdot 10 \text{ hp}}{2\pi \cdot 1,760 \text{ rpm}} = 29.8 \text{ lb-ft} \quad (21)$$

The maximum breakdown torque for the motor (see Table II) is about twice this value.

Fig. 9 shows the electrical torque for an islanding event. Note that torque is about 12 times nominal or 6 times the breakdown torque. Similar results are obtained when inserting the motor into the model of the high-penetration DG example.

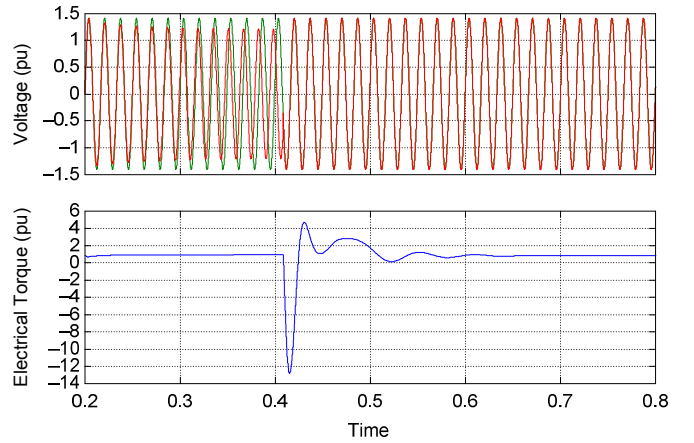

Fig. 9. Motor torque during a reclose with the DG connected

VII. CONCLUSION

The likelihood of out-of-phase reclosing of a distributed generator is very low, but not impossible. For low-penetration DG applications, the major risk is likely the generator itself. For higher-penetration applications, the risk to the DG is reduced. The inrush current in both the low- and high-penetration examples was less than the withstand current of transformers on the feeder. The interrupters that remain closed during islanding are unlikely to be affected because the inrush current seen by these breakers is less than the interrupt rating. However, circuit breakers that are applied in the distribution system are unlikely to have an out-of-phase rating for closing operations, and reclosers are not known to have an out-of-phase rating. Finally, motors that may be connected as loads on the distribution system are likely to be exposed to high transient torques in both low- and high-penetration applications.

VIII. REFERENCES

- [1] Standard for Interconnecting Distributed Resources With Electric Power Systems, IEEE 1547-2003, 2003.
- [2] M. Nagpal, F. Plumtre, R. Fulton, and T. G. Martinich, "Dispersed Generation Interconnection—Utility Perspective," *IEEE Transactions on Industry Applications*, Vol. 42, Issue 3, pp. 864–872, June 2006.
- [3] Z. Ye, A. Kolwalkar, Y. Zhang, P. Du, and R. Walling, "Evaluation of Anti-Islanding Schemes Based on Nondetection Zone Concept," *IEEE Transactions on Power Electronics*, Vol. 19, Issue 5, pp. 1171–1176, September 2004.
- [4] Z. Ye, D. Finney, R. Zhou, M. Dame, B. Premerlani, B. Kroposki, and S. Englebretson, "Testing of GE Universal Interconnection Device," NREL/TP-560-34676, August 2003.
- [5] S. Arefifar, C. Almeida, and W. Xu, "Reclosing Impact on Power Distribution Systems With Operating Distributed Generation," proceedings of the 4th Annual Cigre Canada Conference on Power Systems, Toronto, Ontario, October 2009.
- [6] G. Walsh, "The Effects of Reclosing on Industrial Plants," proceedings of the American Power Conference, 1961.
- [7] IEEE Standard General Requirements for Liquid-Immersed Distribution, Power, and Regulating Transformers, ANSI/IEEE C57.12.00-1987, 1987.
- [8] IEEE Guide for AC Generator Protection, IEEE C37.102-1995, 1995.
- [9] IEEE Standard Rating Structure for AC High-Voltage Circuit Breakers, IEEE C37.04-1999, 1999.
- [10] G. C. Stone, E. A. Boulter, I. Culbert, and H. Dhirani, *Electrical Insulation for Rotating Machines: Design, Evaluation, Aging, Testing, and Repair*. Wiley-IEEE Press, 2004.
- [11] P. C. Krause, W. C. Hollopeter, D. M. Triesenberg, and P. A. Rusche, "Shaft Torques During Out-of-Phase Synchronization," *IEEE Transactions on Power Apparatus and Systems*, Vol. 96, Issue 4, pp. 1318–1323, July 1977.
- [12] H. J. Rohrer, K. E. Schnirel, and I. M. Canay, "Effect of Electrical Disturbances, Grid Recovery Voltage and Generator Inertia on Maximization of Mechanical Torques in Large Turbogenerator Sets," *IEEE Transactions on Power Apparatus and Systems*, Vol. PAS-99, Issue 4, pp. 1357–1370, July 1980.
- [13] Motor and Generators, NEMA MG1-1998, 1998.

IX. BIOGRAPHIES

Dale Williston graduated from the New Brunswick Institute of Technology and began his career with Ontario Hydro in the protection and control department as a protection and control technologist. He was involved in commissioning and maintenance for equipment at distribution stations, transmission stations, and generating stations. Mr. Williston holds two patents for stray voltage solutions. He is still active in that field today, developing and delivering test procedures and training for utilities. In 2000, Mr. Williston took a position with Hydro One Engineering as an engineer/officer developing protection and metering standards for the transmission system. In 2005, Mr. Williston retired from Hydro One and opened Williston & Associates Inc. He is active in distributed generation as a protection and control consultant and is a member of the NRCan Distributed Generation Study Group and the IEEE 1547.8 writing group.

Dale Finney has a bachelor's degree from Lakehead University and a master's degree from the University of Toronto, both in electrical engineering. He began his career with Ontario Hydro, where he worked as a protection and control engineer. Currently, Mr. Finney is employed as a senior power engineer with Schweitzer Engineering Laboratories, Inc. His areas of interest include generator protection, line protection, and substation automation. Mr. Finney has several patents and has authored more than a dozen papers in the area of power system protection. He is a member of the main committee of the IEEE PSRC and a registered professional engineer in the province of Ontario.